

CSS Street Lighting Project SL5/2007
Published Project Report PPR382

Review of the lighting requirement for traffic signs and bollards

J Cooper, K Stafford, P Owlett and J Mitchell





PUBLISHED PROJECT REPORT PPR382

Review of the lighting requirement for traffic signs and bollards

by J Cooper, K Stafford, P Owlett and J Mitchell (TRL)

Prepared for: Project Record: Brief SL5/07
Review for the lighting requirement for traffic signs
Client: CSSLG, UKLB, SCOTS, ILE and TfL

Copyright Transport Research Laboratory October 2008

This Published Report has been prepared for CSSLG, UKLB, SCOTS, ILE and TfL. Published Project Reports are written primarily for the Client rather than for a general audience and are published with the Client's approval.

The views expressed are those of the author(s) and not necessarily those of CSSLG, UKLB, SCOTS, ILE or TfL.

	Name	Date Approved
Project Manager	Jennie Lowe	June 2008
Technical Referee	Ewan Hardman	June 2008

When purchased in hard copy, this publication is printed on paper that is FSC (Forest Stewardship Council) registered and TCF (Totally Chlorine Free) registered.

Foreword

In pursuing its goals of providing advice and guidance to lighting practitioners, the CSS Lighting Group, in partnership with the SCOTS, Transport Scotland, ILE, and TfL has commissioned five research projects to advance some major lighting issues.

With concern for the safety of operatives when working in close proximity to live traffic, increasing maintenance and energy costs, more and more practitioners are questioning the genuine benefits of illuminating traffic signs as currently required by regulation.

This research project was awarded to TRL to investigate the cost / benefit of the illumination of traffic signs across the UK and was managed on behalf of CSS-LG by Lindsay McGregor, Dundee City and Perth and Kinross Councils and Dave Johnson, TfL. The efforts of many individuals in lighting authorities from throughout the UK must be acknowledged for providing invaluable background information to support the work.

A key finding from the project was that some £1.3bn per annum is spent on the maintenance of traffic signs, with only a relatively small proportion of this attributable to energy costs.

While modern retroreflective and other materials may provide a possible channel for future relaxation in regulations governing illumination, there are actions that local authorities can take now that will assist in minimising energy consumption, carbon footprint and the hazards created for operatives when working on lighting installations in close proximity to live traffic.

To accompany the research a guidance document has been produced identifying which specific traffic signs need to be illuminated in different circumstances and provides practical advice on an evolving range of low energy and solar powered lighting solutions.

Since completion of the research, DfT have announced a traffic signs policy review and one aspect of this is the illumination requirements for traffic signs. CSS-LG hopes that this report and accompanying guidance is able to inform that review and proves to be valuable in assisting lighting and traffic engineers in their work.

The guidance document was endorsed by the CSS Lighting Group on 18th June 2008.

CONTENTS

Executive summary	i
1 Overview of research	1
1.1 Introduction	1
1.2 Objectives	2
2 Work Package 1: Review of current documentation and DfT perspective	3
2.1 Introduction	3
2.2 Traffic signs: Statutory lighting requirements	3
2.3 Traffic signs: Official guidance	10
2.4 Traffic bollards: Statutory requirements	11
2.5 DfT perspective	12
2.6 Summary and conclusions	13
3 Work Package 2: Process of obtaining special signs authorisation from DfT for the relaxation of current regulations on an ‘area wide’ basis	15
3.1 Introduction	15
3.2 View of Traffic Signs Policy Branch (TM4)	15
3.3 View of Traffic Signs Technical Branch (TM5)	15
3.4 Summary and conclusions	15
4 Work Package 3: Questionnaire to Local Highways Authorities	17
4.1 Introduction	17
4.2 Methodology	17
4.3 Results	17
4.4 Summary and conclusions	21
5 Work Package 4: Review of practice in other countries	23
5.1 Introduction	23
5.2 Methodology	23
5.3 Results	23
5.4 Summary and conclusions	24
6 Work Package 5: The visual performance of retroreflective materials	27
6.1 Introduction	27
6.2 Geometrical factors affecting the retroreflective performance of traffic signs	27
6.3 Performance index tables from retroreflective material suppliers	31
6.4 Factors adversely affecting the retroreflective performance of signs	34
6.5 Summary and conclusions	36
7 Work Package 6: Practical advice on the use of various types of traffic signs and bollards	39

7.1	Introduction	39
7.2	Traffic signs – introduction	39
7.3	Using LEDs as the light source instead of standard luminaires	39
7.4	Solar powered signs	39
7.5	Electroluminescent signs	40
7.6	Traffic bollards – introduction	42
7.7	Traffic bollards – introduction	42
7.8	Retroreflective self-righting bollard (RSRB)	43
7.9	Solar powered retroreflective self-righting Bollards (RSRBs)	45
7.10	Application of The Construction (Design and Management) Regulations 2007	46
7.11	Pre- installation requirements and considerations	47
7.12	Summary and conclusions	47
8	Work Package 7: Cost benefit analysis	49
8.1	Introduction	49
8.2	Methodology	49
8.3	Results	52
8.4	Summary and conclusions	62
8.5	Further work that could be undertaken	63
9	Recommendations	65
	Acknowledgements	66
	References	66
	Appendix A. Obtaining authorisation for unlit bollards	68
A.1	Instructions to obtain authorisation for unlit bollards in England and Wales	68
A.2	Instructions to obtain authorisation for unlit bollards in Scotland	70
	Appendix B. Sample of questionnaire sent to local authorities	72
	Appendix C. Questionnaire on practice in other countries	73
	Appendix D. Installation instructions for various types of sign	74
D.1	Installation guidance for Solagen Solar Powered sign lighting system:	74
D.2	Installation instructions for One2See’s electroluminescent sign	75
D.3	Installation instructions for TMP bollards	79

Executive summary

A review was conducted by TRL on the cost and benefits which accrue from The Traffic Signs Regulations and General Directions (TSRGD), 2002 requirements for the illumination of traffic signs and traffic bollards. This review was initiated as a result of the development of high performance retroreflective signing materials, which may in some circumstances provide equivalent illumination without the need for direct lighting.

The removal or relaxation of this legal requirement for traffic sign and bollard lighting would have cost benefits to Local Highways Authorities in terms of reduced energy consumption (thus reducing CO₂ emissions), lower traffic sign / bollard installation costs, lower maintenance costs and would also produce less light pollution. It would also reduce the time taken to implement traffic management schemes which involve illuminated street furniture. Maintenance of lamps and lanterns in difficult locations within close proximity to live traffic could be significantly reduced. This needs to be balanced against any genuine benefit in terms of road safety from the direct illumination of signs and bollards.

In order for the study team to develop their recommendations, the following research was undertaken:

Work Package 1 consisted of a review of the current statutory requirements covering traffic sign and traffic bollard lighting and the appropriate British Standards covering both the lighting of traffic signs and traffic bollards. Consultation also took place with the Department for Transport (DfT) to ascertain their views.

Work Package 2 sought to document the process of obtaining official authorisation from DfT on an 'area wide' basis to use traffic signs and traffic bollards without external illumination where this is deemed appropriate and safe.

Work Package 3 involved a questionnaire based survey targeting lighting engineers from a representative group of Local Highways Authorities, in order to ascertain an estimation of the costs and delays incurred into providing permanent lighting for traffic signs and traffic bollards for new traffic safety schemes in lit areas. From this, an estimate of the costs involved across the UK was derived. In terms of cost savings, £5.86 million spent on electricity required to light the traffic signs and bollards could be saved. In addition, some of the £1.29 billion spent on annual maintenance costs could also be saved.

Work Package 4 provided supporting evidence for the case of relaxing the current regulations by establishing 'best practice' in other countries, e.g. there are many EU countries that do not light their traffic signs. This was undertaken by both a literature search and by a targeted questionnaire.

Work Package 5 consisted of a detailed review of the performance of retroreflective materials, carried out in consultation with manufactures and distributors of retroreflective traffic signs. This identified potential situations where the performance is such that it may be appropriate to seek a relaxation of the lighting requirements, but also highlighted the limitations of retroreflective performance in certain driving scenarios.

Work Package 6 provided practical guidance on the use of alternative types of illuminated traffic signs and traffic bollards with low power consumption, such as solar powered or electroluminescent signs, for situations where direct lighting will remain required.

In **Work Package 7** a whole life cost benefit exercise was conducted using the costs of different types of traffic signing material, their luminaires and life expectancy. In addition, the costs and life expectancy of alternative types of illuminated traffic sign, i.e. solar powered or low powered electroluminescent signs was established. It demonstrated that non-illuminated signs are much more cost effective than their illuminated counterparts, but that more modern options such as electroluminescent materials or LED powered illumination were only slightly less cost effective. Additionally, the delay to traffic schemes caused by building power infrastructure for sign lighting had the capacity to significantly detriment the cost effectiveness of any illuminated solution.

A workable guidance document has been produced in order to inform Local Highways Authority engineers on when it is advisable and safe to seek relaxation of the regulations for lighting traffic signs and traffic bollards.

A technical paper (in PowerPoint format) will be produced to include the findings, conclusions and recommendations from this research. This paper will be presented to Local Highways Authorities at a relevant national lighting seminar.

Based upon this research, several recommendations are made:

- Further work should be undertaken to investigate what methods can be used to improve the conspicuity of unlit traffic signs in areas with street lighting, for example the effective use of yellow reflectorised traffic sign backing boards, or providing standard regulatory or warning signs of a larger size.
- Measurements of the conspicuity and legibility of various lit and unlit signs should also be undertaken in order to gather evidence as to whether and when sign lighting is required. This would involve both scientific measurements of luminance and subjective judgments of the visual performance of the signs. Off-road trials could be carried out using TRL's test track facility, and it is likely that the simulator at TRL could be used to carry out an initial study.
- To reduce energy consumption and costs, local highways authorities should conduct an audit of their lit traffic signs and remove unnecessary sign lighting, for example, primary route and non-primary route directional signs, which do not need to be lit in areas with street lighting.
- To reduce energy consumption, costs and traffic sign clutter, local highways authorities should also consider the removal of unnecessary traffic signs.
- To reduce energy consumption and costs, local highways authorities should consider the use of LED or other energy efficient lighting for both externally and internally illuminated signs. The use of solar powered sign lighting and electroluminescent signs should also be considered.
- To reduce installation time and costs, and to increase safety for workers and the general public, local authorities should consider the use of low voltage lighting systems for their externally and internally illuminated signs. This would enable slitting rather than the normal excavation methods to be used.
- In situations where safety is not likely to be compromised and where DfT is likely to give approval for the use of retroreflective self righting traffic bollards, applications from local highways authorities should be encouraged, but it is strongly recommended for safety reasons, these types of non – illuminated traffic bollards are maintained regularly, i.e. the retroreflective faces are cleaned or are replaced immediately if they are damaged.
- Solar powered bollards should also be considered for use instead of traditionally lit bollards, but as these bollards are single sided this should only be done after careful consideration of suitable situations where safety will not be compromised.
- To reduce energy consumption and costs, any bollards or signs not currently 'switched' so that they only illuminate during hours of darkness should have this done as soon as possible.
- Consideration should be made to whether the use of bollards for traffic calming applications, such as pinch points and traffic islands, is always appropriate. If some of these calming measures could be removed this would not only offer a significant cost saving, but also reduce the dangers faced by maintenance operatives who often have to work in the proximity of live traffic. If such work is undertaken, care must be taken to ensure that all bollards necessary for aiding pedestrian crossing and highlighting hazards are retained.

1 Overview of research

1.1 Introduction

Traffic signs need to be clearly visible at night in order that their message is seen by motorists. In areas where the level of background luminance¹ is low (predominantly rural areas), retroreflective material alone is normally adequate to provide sufficient illumination for this purpose. In areas of street lighting, the conspicuity (i.e. quality of an object to stand out from its surroundings) of traffic signs is reduced, as they stand out less against a brighter background. There is, therefore, a legal requirement within the United Kingdom for many traffic signs and traffic bollards to be lit during the hours of darkness if the sign or bollard is within 50 metres of a street lamp that forms part of a system of street-lighting. This is specified in Schedule 17 of the Traffic Signs Regulations and General Directions, 2002 (TSRGD, 2002). With the recent introduction of high performance microprismatic retroreflective signing materials, the necessity for the illumination of traffic signs and bollards needs to be reviewed.

The current legal requirement for illuminating traffic signs and traffic bollards has major cost implications to Highways Authorities in terms of installation costs of the electrical connection, maintenance costs, which can be due to traffic damage and vandalism, plus the additional costs incurred due to the routine replacement of the luminaires. Health and Safety considerations can make maintenance problematic, often requiring lane or road closures to create a safe working environment. Energy costs are also incurred by illuminating the traffic signs and bollards, this energy contributing to CO₂ emissions that have an effect on climate change. The direct illumination of traffic signs and traffic bollards can also have the negative environmental effect of unwanted light pollution.

There has been a significant improvement in the performance of glass bead and microprismatic retroreflective signing material technologies for permanent traffic signs. These retroreflective materials give, under some conditions, high levels of performance in terms of both sign conspicuity and message legibility. With the advancement in technology of both street lighting and retroreflective traffic signing materials, the need for direct lighting requirements for traffic signs and bollards should be reviewed, but extreme care needs to be taken in order to ensure that there is no reduction in the level of safety for motorists driving at night.

This project has been split into seven work packages as outlined below:

Work Package 1 consisted of a review of the current statutory requirements covering traffic sign and traffic bollard lighting and the appropriate British Standards covering both the lighting of traffic signs and traffic bollards. Consultation also took place with Department for Transport (DfT) to ascertain their views.

Work Package 2 attempted to document the process of obtaining official authorisation from DfT on an 'area wide' basis to use traffic signs and traffic bollards without external illumination where this is deemed appropriate and safe.

Work Package 3 involved a questionnaire based survey targeting lighting engineers from a representative group of Local Highways Authorities, in order to ascertain an estimation of the costs and delays incurred in providing permanent lighting for traffic signs and traffic bollards for new traffic safety schemes in lit areas. From this, an estimate of the costs involved across the UK was derived.

Work Package 4 provided supporting evidence for the case of relaxing the current regulations by establishing 'best practice' in other countries, e.g. there are many EU countries that do not light their traffic signs. This was undertaken by both a literature search and by a targeted questionnaire.

Work Package 5 consisted of a detailed review of the performance of retroreflective materials, carried out in consultation with manufactures and distributors of retroreflective traffic signs. This

¹ Luminance is defined in this report using the engineering definition as "the emitted light, projected per unit area, measured in cd/m² (candela per square metre)".

identified potential situations where the performance is such that it may be appropriate to seek a relaxation of the lighting requirements, but also highlighted the limitations of retroreflective performance in certain driving scenarios.

Work Package 6 provided practical guidance on the use of alternative types of illuminated traffic signs and traffic bollards with low power consumption, such as solar powered or electroluminescent signs, for situations where direct lighting will remain required.

In **Work Package 7** a whole life cost benefit exercise was conducted using the costs of different types of traffic signing material, their luminaires and life expectancy. In addition, the costs and life expectancy of alternative types of illuminated traffic sign, i.e. solar powered or low powered electroluminescent signs, was established.

The results of the work packages are presented, along with recommendations of future work that may help attain the aim of a reduction in lighting requirements, and also of methods of saving both energy and costs for signs and bollards that require lighting.

1.2 Objectives

As part of a programme of research funded by The County Surveyors Society Lighting Group (CSSLG), the Society of Chief Officer of Transportation in Scotland (SCOTS), Transport Scotland, the Highways Agency (HA), Transport for London (TfL), and the Institute of Lighting Engineers, TfL have commissioned TRL to review the current regulations requiring the direct illumination of traffic signs and traffic bollards. The work to be undertaken was identified in the project inception report (Mitchell and Cooper, 2008).

There are high costs, both financial and environmental, of illuminating permanent traffic signs and traffic bollards. The development of high performance glass bead and microprismatic retroreflective material means that in some circumstances, equivalent or similar levels of illumination may be provided by these signs alone without the need for direct lighting.

The overall objective of this project is to review the costs and safety benefits of lighting traffic signs and bollards, with a view to identifying circumstances where it might be appropriate to seek a relaxation of the legal requirement to directly light them.

2 Work Package 1: Review of current documentation and DfT perspective

2.1 Introduction

This work package firstly presents a review of the current legislation and official guidance regarding the lighting of traffic signs and traffic bollards. As the Department for Transport (DfT) sets out this legislation and guidance, a meeting took place between TRL and a DfT representative, in order to establish DfT's current position on sign and bollard lighting requirements, ascertain the technical reasons for lighting safety critical signs, and gather their views on the potential for any future relaxation.

2.2 Traffic signs: Statutory lighting requirements

The statutory requirements with regards to the lighting of traffic signs are laid out in Schedule 17 of The Traffic Signs Regulations and General Directions, 2002 (TSRGD, 2002). Within Schedule 17, a 'system of street lighting' is defined as "at least three lamps not more than 183m apart, [185m in Scotland]".

Table 1 details the relevant requirements listed in Schedule 17 as they apply to four types of traffic sign: regulatory signs, warning signs, directional signs and informative signs.

This information can be summarised as follows:

Regulatory Signs

- All regulatory signs, other than speed limit signs and those relating to stopping or parking, are covered by Schedule 17 Item 1 and need to be directly lit if located in a system of street lighting.
- Specific requirements for speed limit signs are set out in Schedule 17, items 10 and 11. Item 10 requires terminal signs² on trunk and principal³ roads to be illuminated by internal or external lighting throughout the hours of darkness when they are located within 50 metres of a street lamp.
 - Other terminal signs, i.e. those on unlit roads and those on lit roads that are not trunk or principal roads, must be either directly lit or reflectorised (Schedule 17, item 11). Again, it is recommended that where a sign is directly lit it is also reflectorised. Where a road has a system of street lighting, but is not a trunk or principal road, it is recommended that speed limit terminal signs are directly lit even though this is not a specific requirement of the Regulations, to minimise the risk that drivers don't see them.
 - Repeater speed sign illumination is also specified in Schedule 17, item 11; signs may be either directly lit or reflectorised. It is unusual for such signs to be directly lit, although this is permitted.
 - 20 mph zone signs may be either directly lit or reflectorised. It is recommended that where the signs are directly lit, they are also reflectorised.

² A terminal speed limit sign is that which marks the change of a speed limit, e.g. from the national speed limit to 40mph.

³ A principal road is any road with an "A" number that isn't a trunk road

Warning signs



- These signs fall within the scope of Item 1 or Item 4 of Schedule 17.
- Those warning signs within Item 1 usually indicate danger which is always or very frequently present (e.g. sign 543 traffic lights ahead) and, until the 2002 revision of TSRGD, all these signs required to be directly lit if located in a system of street lighting.
- Many of these warning signs no longer need to be lit when they are located on a single carriageway, non-principal road where the speed limit is 30mph or less. Those that still require lighting in all circumstances are listed in Table 1.
- Those warning signs within Item 4 tend to indicate potentially dangerous situations that sometimes or infrequently occur, and are required to be either reflectorised or directly lit. An example would be sign 558 warning of low flying aircraft. These signs are considered less safety critical.



Directional Signs

- All directional signs, except tourist destination signs, fall under Schedule 17 Item 4, and so must be either directly lit or reflectorised. Tourist destination signs do not require lighting.

Informatory Signs

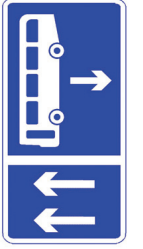
- Most fall under Schedule 17 Item 4 and again are required to be either directly lit or reflectorised – the exceptions are signs aimed at pedestrians and cyclists, which fall under Item 9 and do not require either.

Type of sign				
	Regulatory	Warning	Directional	Other
<p>TSRGD, 2002 Schedule 17 (Illumination requirements)</p> <p>If the sign is within 50 metres of a street lamp that forms part of a system of street-lighting, (at least three lamps not more than 183m apart, [185m in Scotland]) it must be lit and may be reflectorised. (Item 1)</p> <p>If the sign is within 50 metres of a street lamp that forms part of a system of street-lighting, (at least three lamps not more than 183m apart, [185m in Scotland]), and is on a single carriageway non-principal or trunk road with a speed limit of 30mph or less it must be either reflectorised or lit. (Item 1)</p> <p>If the sign is erected on a road, is a terminal sign, and if the sign is within 50 metres of a street lamp that forms part of a system of street-lighting, (at least three lamps not more than 183m apart, [185m in Scotland]) it must be lit. If not required to be lit it must be reflectorised</p>	 <p>All except those listed under items 4,9,10 and 11 below</p>	 <p>501 (give way or stop ahead), 530, 531.1, 532.2, 532.3, (bridge heights) 543, (traffic lights) 544, 544.1, 544.2 (pedestrian presence) 555 (river or quayside ahead), 950 (cycle route ahead) In general, all other signs to warn of road geometry (such as warnings of bends, humps, gradients etc), that are not listed in the row above.</p>	 <p>-</p>	 <p>Sign 953 (route for use by buses and pedal cycles only), 953.1 (route for use by tramcars only)</p> <p>-</p> <p>955, 956, 957 (Route for pedal cycles only, or shared use between cycles and pedestrians)</p>

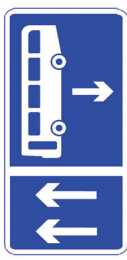
TSRGD, 2002 Schedule 17 (Illumination requirements)		Type of sign			
		Regulatory 	Warning 	Directional 	Other 
Regardless of street lighting provision, the sign may be externally or internally illuminated, otherwise it shall be reflectorised. (Item 4)	642.2A, 642.3 (Yellow no stopping signs), 646,647,650.1 (Urban clearways) 663,663.1,664,665,666, (Controlled Parking Zones)	In general, any sign to warn of external dangers outside of the road itself (e.g. animals, soft verges, possibility of low flying aircraft), but this also includes signs warning of slippery road surface and uneven road.	All primary route directional signs, non primary route directional signs, and signs for services and tourist facilities.	Signs related to bus/cycle lanes aimed at drivers Any informative signs aimed at drivers. Signs indicating bus or cycle lanes aimed at drivers (except those in item 1 above, Signs for bus/tram etc stop. Any signs aimed specifically at cyclists/ pedestrians.	
Regardless of street lighting provision, the sign may be illuminated by external/ internal lighting or may be reflectorised or left unlit (Item 9)	Any other Loading, Waiting or Parking signs. Signs aimed at horses or pedestrians 622.5, 622.6, 625.1, (no horses, no horse drawn vehicles and no pedestrians)	-	Tourist destination signs		



TSRGD, 2002 Schedule 17 (Illumination requirements)	Type of sign			
	Regulatory 	Warning 	Directional 	Other 
If a speed limit sign is a terminal sign, and is located within 50m of a street light, and the road is a principal or trunk road, then it shall be either: i) Internally or externally illuminated throughout all hours of darkness and may be reflectorised, OR ii) be externally illuminated while the street lamp is lit and also reflectorised (Item 10)	Maximum and minimum Speed Limit signs, excluding those for 20 mph zones	-	-	-
If a speed limit sign is not required by Item 10 to be lit, then it may be lit, but if not it shall be reflectorised. (Item 11)	All maximum and minimum Speed Limit signs, including those for 20 mph zones	-	-	-

Table 1: Summary of the requirements prescribed in TSRGD, 2002 Schedule 17 for the lighting of traffic signs

While TSRGD, 2002 Schedule 17 details the situations where direct illumination is required, it does not provide any details on the level of illumination required for traffic signs and traffic bollards. This is set out in the relevant British Standards.

Figure 1 below shows how British Standards apply to the lighting of Traffic Signs and Traffic Bollards.

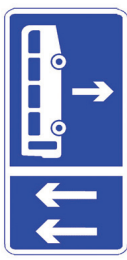
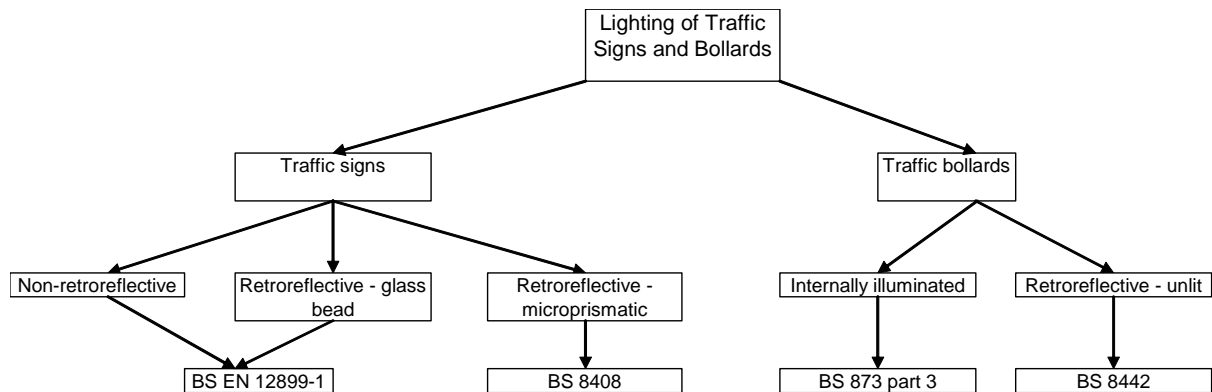

Figure 1 – The application of British Standards to the lighting of traffic signs and bollards

BS EN 12899-1: 2007 specifies performance requirements for non-retroreflective signs, transilluminated and glass bead retroreflective signs. Within this document, the National Annex states the recommended performance values of external and internal luminaires, and glass bead retroreflective signs in different circumstances in the UK.

There are two classes of glass bead retroreflective material; Class Ref 1 is of lower specification and is suitable for areas of low background luminance (i.e. away from street lighting). Class 2 ref material is suitable for areas of medium and high background luminance. The required coefficients of retroreflection in various geometrical situations for a range of colours are given in BS EN 12899-1: 2007 (Tables 8 and 9) for Class Ref 1 and Class Ref 2 respectively.

This British Standard states that where external lighting is deemed necessary, the signs are to be reflectorised with Class Ref 2 material so that in the event of luminaire failure, the sign has adequate visibility.

Table 2 below shows which type of retroreflective material is required as well as the level of luminance required from internal and external light sources on the white portion of the sign for low, medium and high levels of background luminance.

	Level of Background Luminance		
	Low	Medium	High
Type of retroreflective material required	Class Ref 1 – Table 8 in BS EN 12899-1: 2007		Class Ref 2 – Table 9 in BS EN 12899-1: 2007
Level of luminance required from external lighting	Not recommended	25-150 cd/m ²	100 – 350 cd/m ²
Mean level of luminance required from Internally illuminated signs	Not recommended	40 – 150 cd/m ²	150 – 300 cd/m ²

Table 2 – Requirement for luminance level of the light sources of signs

In practice the required values in areas of high background luminance are unachievable with externally lit signs, and very hard to achieve with internally lit signs, and so most perform in accordance with the medium category. It should be noted that the luminance figures for externally lit signs relate to luminance values on a white reference panel. This has a luminance factor⁴ of 0.85, whereas Class Ref 2 (i.e. glass bead) sheeting has a luminance factor of about 0.30 when new. Therefore the observed luminance on a traffic sign will be of the following ratio to that given in the tables above:

$$\frac{0.30}{0.85} \approx 0.35$$

Table 3 below shows the luminance levels of the sign faces when this factor is taken into account.

	Level of Background Luminance		
	Low	Medium	High
Level of luminance required from external lighting	Not recommended	9-53 cd/m ²	35 – 123 cd/m ²
Mean level of luminance required from internally illuminated signs	Not recommended	40 – 150 cd/m ²	150 – 300 cd/m ²

Table 3 – Actual luminance levels of traffic signs when lit in line with the requirements

From this table, it is clear that the minimum level of required luminance of the white portion of an externally lit sign is 9 cd/m².

It should be noted that for fixed signs BS EN 12899-5 & 6: 2007 also apply though these do not deal solely with luminance.

BS8408 is the British Standard for microprismatic retroreflective sheeting. It is important to note that this applies only to the sheeting and is in addition to BS EN 12899 - 1, 5 and 6: 2007. It is unusual in that rather than specify performance requirements for traffic signs in a laboratory environment, it considers how these retroreflective materials are used on the road. The standard sets different performance requirements for different types of signs, in different positions, for different types of vehicle, based on driver needs. Research was undertaken by the working group that produced this standard which indicates that at longer distances, a luminance of about 10 cd/m² is required for traffic signs to be legible (i.e. readable). To be conspicuous (i.e. to stand out from the background) on unlit roads, signs were found to require luminance levels of the order of 3 cd/m² and it was estimated that about 3 times as much light would be required in lit areas. This led to the concept of the *performance index*. This specifies the level of luminance needed on signs on lit and unlit roads. The performance of a sign at a particular location can be calculated, and if it fails to meet the minimum requirement specified in Table 4 below it needs to be lit.

Sign Type	Minimum performance index value	
	Unlit road	Lit road
Directional sign	1.0	1.0
Regulatory / Warning sign	1.0	3.0

Table 4 – The Performance Index of signs on lit and unlit roads

⁴ Luminance factor is the ratio of the luminance of a body when illuminated and observed under certain conditions to that of a perfect diffuser under the same conditions. The higher the value, the more of the incident light is emitted by the body.

A performance index (P.I.) of 1.0 corresponds to a luminance of approximately 3cd/m^2 . The relationship is linear, so a P.I. of 3.0 corresponds to approximately 9cd/m^2 . This ties in with the minimum required figures of sign luminance for externally lit glass bead signs given in BS EN 12899-1: 2007.

In order to calculate the performance index, five pieces of information about the sign are determined. Each piece of information is selected from a list of values. The following needs to be determined:

- The viewing distance range – i.e. how far away the sign will be viewed from its physical position. This depends on the typical traffic speed of the road. For example on a 70mph dual carriageway, a driver will be able to view a sign from about 200m down to about 50m from its position, while in a 20mph zone, the viewing distance will be from about 50m to 20m. There are four possible distance ranges specified; long, medium, short and close.
- The entrance angularity – this is the maximum entrance angle⁵ of a sign relative to an approaching vehicle while the vehicle is in the viewing distance range specified above. There are four classes of entrance angularity; straight – for angles up to 5° , narrow – for angles up to 15° , medium – for angles up to 30° and finally wide – for angles up to 40° .
- The sign category – The two basic categories of sign are those with a legend and those which are mostly symbolic. The former require individual letters to be read and therefore requires a higher degree of legibility.
- Vehicle Type – There are two classes of vehicle type; passenger cars and large vehicles. As the driver is located further from the vehicle headlights in large vehicles, and suffers from poorer retroreflective performance of signs, the value of retroreflectivity is lower for these vehicles. The level of use of the road by lorries at night is the principal determining factor of which class is used – if it is a very low value, then the value for passenger cars may be used.
- Sign Location – The amount of light received by a sign from vehicle lights depends to a large degree on its position. Four standard positions exist; left verge, right verge, overhead and low left.

The values, which are to be found in appropriate tables in BS8408, are extracted and multiplied to give the performance index of the sign in the location. Thus, using Table 3 above, it can be determined whether the sign requires lighting. Work package 5 contains a detailed study of retroreflective performance and all the factors affecting it.

2.3 Traffic signs: Official guidance

The statutory requirements laid out in Section 2.2 give the situations where lighting *must* be used, and in that sense, following them exactly is carrying out the minimum requirements. Chapters 3 and 4 of the Traffic Signs Manual provide practical guidance on the application of Regulatory and Warning signs respectively. Both point out that although modern microprismatic materials achieve high luminances for many drivers in defined situations, they do not do so for all drivers in all circumstances. Thus, it is recommended that beyond the requirements of TSRGD, 2002 Schedule 17,

⁵ Entrance angle is the angle between the vehicle headlights beam to the sign and the normal to the sign, which is perpendicular to the sign face

there are other situations where direct lighting of signs may be considered desirable, and detail some of these situations. The revised version of Chapter 3, currently in draft form⁶, states:

“...some signs may be sited where they will not receive adequate illumination from headlamps, and it might be prudent to provide direct lighting regardless of the regulatory requirements. Examples include signs mounted unusually high above the level of the carriageway, on the off side of the road or at the entrance to a side road.” (Department for Transport, 2007a)

Chapter 3 also recommends the lighting of **all** speed limit terminal signs in lit areas, to minimise the risk of them not being seen, even though this is above and beyond the requirements set out in Schedule 17 of the TSRGD, 2002:

“Where a road has a system of street lighting, but is not a trunk or principal road, it is recommended that speed limit terminal signs are directly lit even though this is not a specific requirement of the Regulations, to minimise the risk that drivers don't see them.” (Department for Transport, 2007a)

The use of warning signs should be considered carefully. Chapter 4 states the following:

“Appropriate warning signs can greatly assist road safety. To be most effective, however, they should be used sparingly. Their frequent use to warn of warn of conditions which are readily apparent tends to bring them into disrepute and detracts from their effectiveness”

The DfT have stated that it is essential that any unnecessary signs should be removed, for the above reasons (See Section 2,5 below). Many unnecessary warning signs are currently installed in areas of street lighting. Those that require lighting are needlessly adding to both costs and the carbon footprint of local authorities.

2.4 Traffic bollards: Statutory requirements

The lighting requirements for internally illuminated bollards are set out in British Standard BS 873 Part 3⁷. Two lamps operated on independent, separately fused circuits must be used so that in the event of failure of one bulb, illumination of the bollard still occurs. Table 5 below details the illumination requirements, which ensure sufficient and uniform lighting, and therefore an acceptable level of bollard conspicuity, and legibility of the symbol. The term luminance ratio means the maximum luminance divided by the minimum luminance in the specified area.

Mean Luminance of the white portion of the prescribed sign	175 cd/m ² – 425 cd/m ²
Mean Luminance of the yellow portion of the body	125 cd/m ² – 300 cd/m ²
Maximum Luminance Ratio of the white portion of the prescribed sign	2.5 : 1
Maximum Luminance Ratio of the yellow portion of the body	8 : 1
Luminance of the coloured portion of the sign as a percentage of the luminance of the white portion	Red: 5% - 15% Blue: 2% - 10%

Table 5 – Requirements for the illumination of bollards

⁶ This document is due for publication in September 2008

⁷ This standard has recently been superseded by BS EN 12899-2:2007

The last few years have seen the introduction of the retroreflective self-righting bollard (RSRB). In certain circumstances these non-illuminated bollards are now allowed to be used in place of traditional bollards. In order to use them it is first necessary to receive authorisation from DfT. Each local highway authority is required to apply separately and DfT will not accept submissions on behalf of multiple highways authorities. One of the retroreflective bollard manufacturers, Traffic Management Products (TMP), provides instructions on how this is achieved and these are attached in Appendix A.

If approved, these bollards can be used in the following situations:

- In any location which falls outside a Street Lighting Scheme i.e. over 50m from a lighting column
- Centre Islands/Refuges when used in conjunction with a Centre Island Column with an independently lit D610 (keep left) sign
- Side Road Junctions when used in conjunction with a Centre Island Column with an independently lit D610 (keep left) sign
- In front of Traffic Signals without any supplementary signage or lighting

BS 8442 sets out the required specification for these bollards. The conspicuity panels are required to be coloured fluorescent yellow and be highly retroreflective in order to aid both daytime and night-time conspicuity. The performance index is required to be 9.0 for a car when viewed from small entrance angles at a short distance range. This is significantly higher than the requirement for signs, but due to bollards occupying a low position, and so receiving a large amount of illumination from car headlights on dipped beam, quite easily achievable with modern retroreflective materials. It is, however, legal to drive using sidelights; these would not cast enough illumination on to the bollards in order for the required luminance levels to be met.

2.5 DfT perspective

It is clear from discussions with DfT that their prime concern is for the safety of road users. With the increase in performance of retroreflective sign face materials, the requirement to light some warning signs in some circumstances has been removed. These, however, are signs considered to be less critical to safety and those which have little relevance at night. For example, signs warning of the potential presence of horse riders do not require lighting as they almost never use the roads after the hours of darkness. Round regulatory signs and those warning signs considered safety critical still require lighting. Having reviewed the requirement to light warning signs in the current issue of The Traffic Signs Regulations and General Directions (TSRGD), issued in 2002, DfT currently have no plans to do so again in the near future.

It is also important to note that retroreflectivity does not work for signs that are not facing the traffic at which they are aimed. Examples of situations in which this occurs are "No entry" signs on side roads and "One way" signs (diagram 652) close to a junction from which traffic enters the one-way street.

The quality of street lighting has improved in recent years, increasing the ability to distinguish colours and the chance of reading signs correctly. However this has also led to an increase in the overall level of background illumination, which is contributed to further by improvements in the lighting of shop frontages. As described in Section 6.4.4, this renders signs less conspicuous and requires them to be even brighter to stand out.

Most other EU states have far less stringent rules regarding the lighting of signs and bollards. As shown in Figure 2 below, most also have far higher accident rates, and so DfT have no plans to align lighting requirements with other EU states. Street lighting coverage is patchier in many other EU countries and therefore the level of background illumination is often significantly lower. There are also key differences in the evolution of the road networks; for example the use of bollards to create traffic islands to aid pedestrians crossing and delineate traffic is almost unique to the UK. Direct comparisons with other states can therefore be misleading.

It was suggested that there might be some retroreflective warning and directional signs lit unnecessarily, presumably because when the signs were originally installed the sign faces were not retroreflective and so required lighting. Local authorities may wish to carry out an audit of their signs and remove lighting where allowed by the current regulations. Furthermore, the DfT consider there are many warning signs that are correctly lit, in line with the requirements, but which are not required at all. An example given was a sign of type 507.1 in a suburban area, indicating a staggered junction ahead. It is reasonable to expect junctions in that type of area, especially when it is lit. An audit may also wish to consider potentially removing warning signs which are unnecessary, while ensuring that no signs offering genuine safety benefits are removed.

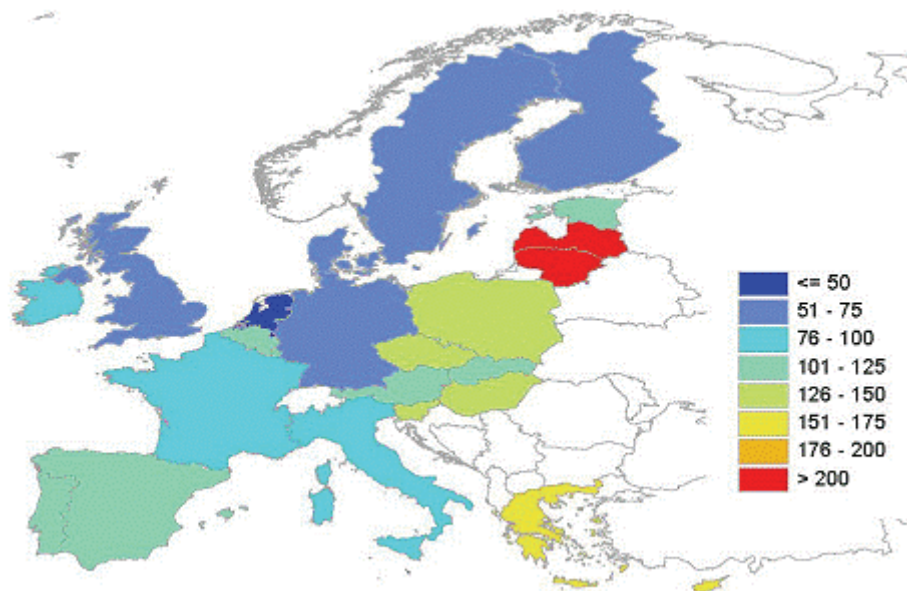

Figure 2 – Road fatalities in EU countries per million inhabitants, 2004 (Source: European Road Safety Observatory)

2.6 Summary and conclusions

Balanced against the costs of the provision of direct lighting for signs are the safety case for doing so, and the implications for potentially increased casualty figures if this is not done. It is clear that the current regulations and official guidance are weighted towards casualty reduction and in favour of the safety case. TSRGD (2002) requires all regulatory sign roundals aimed at drivers⁸ to be directly lit, when located in a system of street lighting. Terminal speed limit signs require direct lighting when located on a principal or trunk road in a street lit area. The current draft of Chapter 3 of the Traffic Signs Manual (this is due for publication in September 2008) recommends also the lighting of all

⁸ The regulatory sign roundals this does not apply to are those banning pedestrians, horses and horse drawn vehicles from a road, aimed at those road users.

terminal speed limit signs situated in lit areas. While in recent times some warning signs have been exempted from the requirement for direct lighting on non-principal or trunk roads with a speed limit of 30mph or less, DfT have made it clear that this is not to be interpreted as the start of a wider move to end the use of directly lit signs.

Although high performing microprismatic and glass bead retroreflective materials are now available and in wide use, they do not provide equivalent illumination to direct lighting in all circumstances, particularly for the drivers of large vehicles (for a detailed investigation into their performance see Work Package 5). Therefore, for safety critical signs, direct lighting is still required. Nonetheless it is worth noting that no directional or informatory signs require lighting, and that many warning signs no longer require lighting in street lit areas if located on a single carriageway non-principal road with a speed limit of 30mph or less.

Retroreflective self righting bollards (RSRBs) may now be used in some locations instead of the traditional lit bollards. These circumstances are listed in Section 2.4 above. Before using these bollards, each local highways authority wishing to do so must obtain special signs authorisation from DfT.

3 Work Package 2: Process of obtaining special signs authorisation from DfT for the relaxation of current regulations on an ‘area wide’ basis

3.1 Introduction

One of the main project aims outlined in the brief was to document the process of obtaining special signs authorisation on an ‘area wide’ basis for the use of retroreflective traffic signs and bollards as an alternative to illumination. With this aim in mind, consultation took place with the Department for Transport (DfT) to determine the feasibility of this.

3.2 View of Traffic Signs Policy Branch (TM4)

Contact was made with the head of the Traffic Signs Policy Branch (TM4) of DfT. A phone conversation took place during which the project brief was discussed, as well as the possibility of relaxing the requirement to light signs on an area wide basis.

Regarding the project brief, it was stated that this was too wide for it to be considered by TM4. DfT would require a lot of evidence to be gathered proving that retroreflective material provided sufficient illumination in order to relax the current requirements to light signs. It was stated that there would need to be a partnership between DfT and the agencies involved in the commissioning of this project to facilitate the gathering of evidence for this purpose. As regards reducing the current requirement to light signs, for legal reasons DfT consider each type of sign individually on a national basis and currently have no plans to review these requirements. Again for legal reasons, DfT would require an element of control if special authorisation to not light signs was to be granted, so it would not be on an area wide basis, but on a sign by sign basis.

As regards the application to install unlit bollards, legal requirements dictate that each authority applies individually, and it was clear that DfT would reject any submission on behalf of multiple authorities.

Due to the nature of this project, these issues were referred to DfT’s Traffic Signs Technical Branch.

3.3 View of Traffic Signs Technical Branch (TM5)

A meeting took place between the head of the Traffic Signs Technical Branch (TM5) of DfT and TRL.

It was confirmed by DfT that the maximum ‘area’ a special signs authorisation can be applied to is a local highways authority. This is determined by the legal powers of DfT and they have no control over it. They are therefore unable to issue a special signs authorisation for the whole of the UK, even if persuaded by the arguments to do so. Therefore each authority will have to continue to apply separately.

3.4 Summary and conclusions

For existing special signs authorisations, DfT are unable to issue special signs authorisations on a national basis or to multiple local highways authorities at the same time because of legal restrictions placed upon them, so each local authority will have to continue to apply individually.

In terms of authorising the removal of lighting from traffic signs, each sign is individually assessed and the lighting requirements for that sign are set out on a national basis, with no scope for local variations. If any signs that normally required lighting were to be exempted, then this would have to be done on a sign by sign basis. In practice, DfT would not currently agree to do this. There are no plans to review sign lighting requirements in the near future, and at the current time DfT remain unconvinced of the case for removing lighting from those signs that require it. From DfT’s viewpoint,

safety is the prime concern, and so in order to reduce the requirement for direct lighting, a large scale study would be required proving that retroreflective materials offer similar levels of illumination to direct lighting.

4 Work Package 3: Questionnaire to Local Highways Authorities

4.1 Introduction

A questionnaire was sent to lighting engineers from a representative sample of local highways authorities in order to establish the costs and problems associated with both the installation and maintenance of illuminated traffic signs and bollards.

4.2 Methodology

The questionnaire was designed to gather the costs and problems associated with illuminated traffic signs from local authority lighting engineers. It included questions on the costs associated with the installation of new illuminated and non-illuminated signs and bollards, maintenance costs and delay to traffic schemes caused by the requirement to light signs and bollards. It also contained questions on the length of highway run by the authority and the number of illuminated signs and bollards in the area. This information was gathered so that the costs could be extrapolated for the whole country. A sample of the questionnaire is included in Appendix B.

The questionnaire was sent to lighting engineers from a sample of local highways authorities. This included London authorities, rural authorities and urban unitary authorities from England, Scotland, Wales and Northern Ireland. Responses were received back from Hackney, Lewisham, Lincolnshire, Gloucestershire, Durham, Leicestershire, Cardiff, DRDNI, Manchester, Bexley, Dudley, Perth and Kinross, West Lothian, Caerphilly and Cheshire.

The results were entered into a database for analysis.

4.3 Results

4.3.1 *Difference in cost between illuminated and non-illuminated signs*

Figure 3 shows the estimates of costs of installing illuminated and non-illuminated traffic signs provided by the different local authorities. This data suggests that the average additional cost of installing an illuminated a sign is £689 i.e. installing an illuminated sign costs on average 300% more than installing a non-illuminated sign.

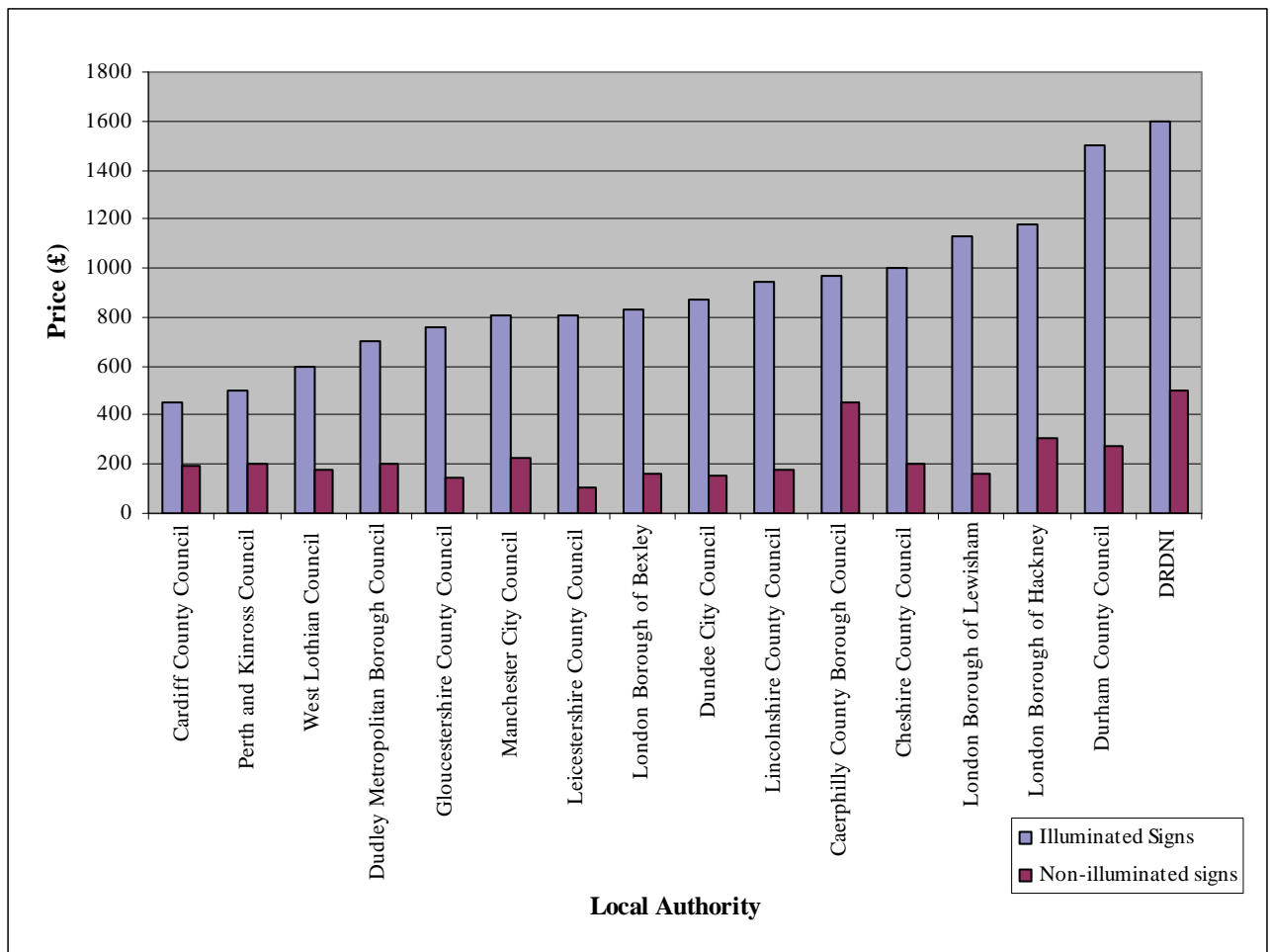

Figure 3 - Price of installing illuminated and non-illuminated signs

4.3.2 Difference in cost between illuminated and non-illuminated traffic bollard

Figure 4 shows the estimates of costs for illuminated and non-illuminated traffic bollards provided by the different local authorities. This data suggests that the average additional cost of installing an illuminated bollard is £486 i.e. installing an illuminated bollard costs on average 200% more than installing a non-illuminated bollard.

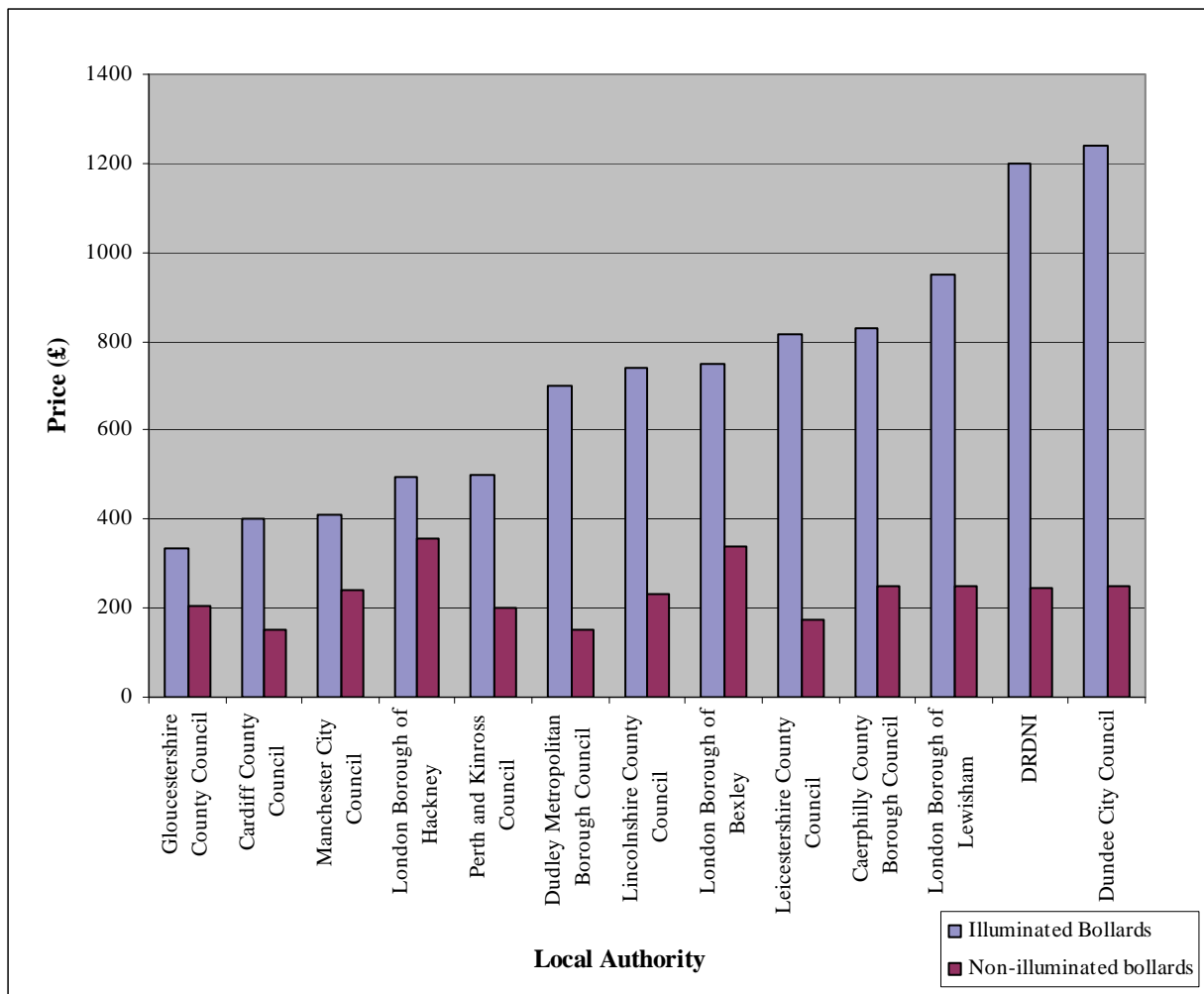

Figure 4 - Costs of installing illuminated and non-illuminated bollards by local authority

4.3.3 How much longer does it take to implement a highway safety scheme due to the current requirement to provide electrical supply to illuminate traffic signs and bollards?

There was a large range of responses to this particular question with the smallest being no time and the largest up to 4 months. However, the general consensus between the answers seems to point to an average delay of around 2 months.

4.3.4 Maintenance budget for illuminated signs and bollards

Figure 5 shows the results of dividing the annual maintenance budget for an area by the sum of the number of bollards and the number of signs in the area to find an approximate cost per item for maintenance.

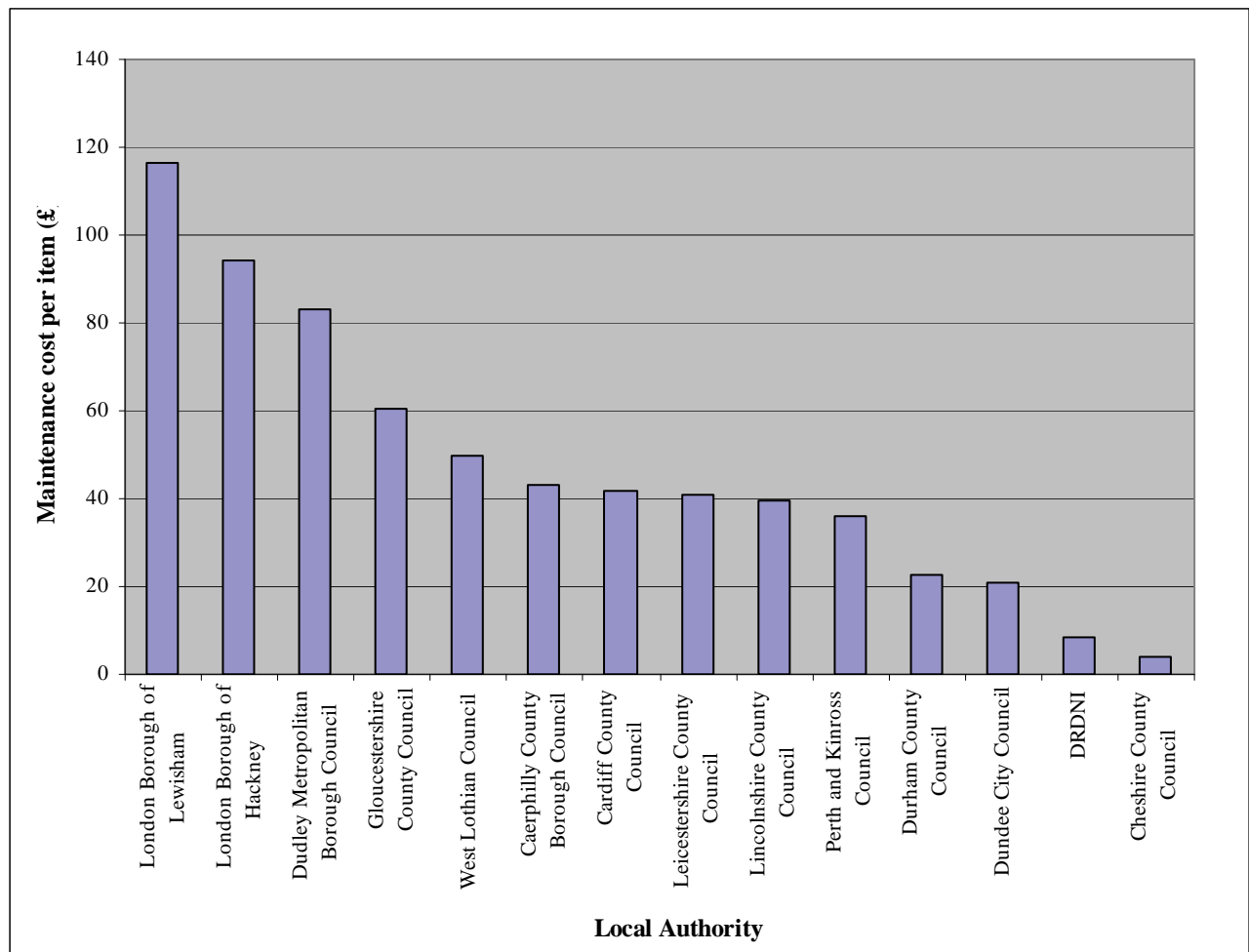

Figure 5 - Maintenance cost per sign/bollard by local authority

The cost of maintenance in each area was divided by the length of road in the area. This figure was multiplied by the length of road in the whole of the UK (394,213 km in Great Britain (Department for Transport, 2007b) + 25,188 km in Northern Ireland (Source: questionnaire from DRDNI) = 419,331 km). This gave a total figure for annual maintenance in the whole of the UK as **£1.29billion**. If signs were no longer illuminated some of this would still have to be spent on cleaning non-illuminated signs etc. but there would no longer be any need to change lamps etc. so the maintenance costs would be less.

It is felt by practitioners that most of the annual maintenance budget is currently spent on illuminated signs, not only in lamp inspection and changing but also in carrying out compulsory electrical testing. This means that in spite of the high maintenance spend, many traffic signs and bollards do not enjoy high levels of regular maintenance. Therefore it follows that all signs and bollards could be better maintained if the statutory lighting requirement was removed, while still potentially saving money.

The total energy used to light signs and bollards each year in the UK is around **65 GWh**. This assumes that signs and bollards are illuminated for 4200 hours each year (around 11.5 hours each day) and that signs require 24W of electricity whilst bollards require 33W. The figure for signs is an average of figures quoted by Simmonsigns for their different products whilst the figure for bollards is the most common figure quoted by Signature Bollards. The number of hours of illumination was multiplied by the power rating and the number of bollards and signs in the UK (extrapolated from the questionnaires) to calculate the figure above. The cost of this electricity (assuming electricity costs nine pence per kWh) is **£5.86million**.

4.4 Summary and conclusions

In summary, if traffic signs and bollards were no longer illuminated the following savings could be made:

- Each new traffic sign installation would cost on average £689 less
- Each new traffic bollard installation would cost on average £486 less
- A significant proportion of the £1.29 billion spent on annual maintenance costs could be saved
- The £5.86 million of electricity costs for signs and bollards each year could be saved
- New traffic schemes could take on average two months less to implement

5 Work Package 4: Review of practice in other countries

5.1 Introduction

The regulations and practice in other countries were reviewed by means of a targeted questionnaire and by a literature search.

5.2 Methodology

A questionnaire was designed with questions that focussed on what requirements there are to light traffic signs in a specific country, whether there are special circumstances in which signs are lit and whether any low powered signs and bollards are used.

This questionnaire was sent to countries in Europe and North America where TRL had established contacts. A copy of the questionnaire is included in Appendix C.

A summary of the information on illumination of traffic signs in Europe is also given. The IMPROVER report (Horberry and Mitchell, 2006) was an EU funded research project related to the harmonisation of traffic signs on the Trans-European Road Network (TERN) from a safety point of view.

5.3 Results

Completed questionnaires were received back from Denmark, Sweden, Portugal, The Netherlands, Hungary, Ohio and France. A summary of each response is given below along with information taken from the IMPROVER report from countries where sign lighting is used.

5.3.1 Denmark

There is no general requirement to light traffic signs or bollards. However one particular sign, which is found at pedestrian crossings, must always be illuminated.

5.3.2 Sweden

There is no requirement to light traffic signs or bollards. Instead retroreflective sheeting is often used in areas with lots of background light. Better retroreflective sheeting or, very occasionally, external lighting is used to make signs more conspicuous.

5.3.3 Portugal

There is no requirement to illuminate traffic signs or bollards. Lighting is sometimes used in areas with high accident risk. In urban areas, directional panels are sometimes illuminated and in a few cities, signs are made more conspicuous by the use of better retroreflective materials or more conspicuous colours. Examples of the more conspicuous colours used are: fluorescent lemon-yellow and fluorescent lemon-green. LED technologies are sometimes used and these are in general solar powered.

5.3.4 The Netherlands

Although there is no requirement for traffic signs and bollards to be illuminated, lighting is sometimes used for example at dangerous pedestrian crossings. Reflective sheeting class III is used in towns/cities with high levels of background illumination.

5.3.5 Hungary

Traffic signs are occasionally illuminated at the discretion of regional traffic authorities. However, new illuminated signs are only allowed to be placed where there has previously been an illuminated sign or on traffic lamps.

In the past, signs were made more conspicuous in towns and cities by internal lighting. This is no longer a requirement and signs in towns and cities are now either internally or externally illuminated or retroreflective over their whole surface. Requirements state that signs on the same post must have the same visibility and it is strongly recommended that signs on the same road are the same visibility. Technology has been trialled for solar powered signs with accumulators for high risk areas such as level crossings. However, these are not currently in use.

5.3.6 France

Traffic signs are generally retroreflective and not illuminated. However, lighting is sometimes used in areas where there is a high risk of accidents. If lighting is used, for external lighting the sign face must be covered with retroreflective sheeting of high intensity grade and for internal lighting the sign face must be translucent and retroreflective. There are no regulations for bollards as these are rarely used.

5.3.7 USA

Laws in the USA vary from state to state. In Ohio all signs are made of retroreflective sheeting. There is no law regarding lighting of signs, as lighting is not provided for signs.

5.3.8 Germany

Some regulatory and warning signs in built up areas and on the offside of the road must be illuminated. These signs must also be made of microprismatic retroreflective material. All direction signs on main roads in build up areas should also be illuminated.

5.3.9 Belgium

Signs above 5m must be illuminated.

5.3.10 Latvia

Direction and information signs above 3m must be illuminated. Signs are sometimes illuminated in areas with a high risk of accidents.

5.3.11 Greece

Some signs are illuminated in areas with a high accident risk.

5.4 Summary and conclusions

In most other European countries there is no legal requirement for the illumination of signs and bollards. Instead retroreflective sheeting is used and in some countries lighting is used on a few signs – usually those located in dangerous or less visible areas such as accident blackspots or mounted high above the road.

The only exception to this is Germany, where some regulatory and warning signs in built up areas or on the offside of the road and directional signs must also be illuminated.

A summary of the sign lighting requirements for some EU countries and one US State are shown in Table 6:

Country	Illumination in built-up areas	Illumination of high mounted signs	Illumination in high accident risk areas	Illumination of particular signs	Illumination in areas with high background illumination	Signs on offside of road
Austria						
Belgium		Signs above 5m				
Denmark				Pedestrian crossing signs		
Estonia						
Finland						
France						
Germany	Some regulatory and warning signs, direction signs					Some regulatory and warning signs
Greece						
Hungary					Internal illumination previously required	
Ireland						
Latvia		Direction / information signs above 3m				
The Netherlands						
Portugal	Direction signs					
Spain						
Sweden						
USA (Ohio)						

Colour key:

	Lighting sometimes used
	Regulation requirement for illumination

Table 6: Summary of sign lighting requirements for different countries

6 Work Package 5: The visual performance of retroreflective materials

6.1 Introduction

In recent years there have been significant improvements in the performance of both microprismatic and glass bead retroreflective materials. In specific circumstances, these materials can potentially offer similar levels of luminance to directly lit signs, and so offer the prospect of reduced need for direct lighting. In order to ascertain their strengths and limitations, and how these materials perform in various traffic scenarios, major manufacturers and suppliers of these retroreflective materials were consulted. To this end meetings were held with representatives from Avery-Dennison, Rennicks and 3M (UK).

In this work package, it is first discussed how the geometry between vehicles, sign position and drivers in roadside scenarios affects the visual performance of retroreflective material. Manufacturers' own test data for their highest performing microprismatic retroreflective material is then analysed to identify scenarios where the performance index identified in BS 8408 is met, and similar levels of illumination are provided by retroreflectivity alone to that when direct lighting is present. Other factors that may reduce the retroreflective performance of signs are then considered. The summary and conclusion considers, in the light of these findings, under what circumstances it may be considered appropriate to consider a relaxation of the requirement to light signs.

It is worth noting that throughout the rest of this work package it is assumed that the signs in question are facing the traffic at which they are aimed. Whilst this is usually true, as pointed out by DfT during consultation, it is not always so. Examples of situations in which this occurs are "No entry" signs on side roads and "One-way traffic" signs close to a junction from which traffic enters the one-way street. In such situations, the retroreflective properties of the sign will not work, and direct lighting will be required.

6.2 Geometrical factors affecting the retroreflective performance of traffic signs

Modern retroreflective materials potentially offer high enough levels of luminance to reduce the need for the direct lighting of signs. The best microprismatic materials offer better visual performance than their glass bead equivalents, and are increasingly in use on the road network. However, as Chapter 3 of the Traffic Signs Manual states:

“Although modern microprismatic materials achieve high luminances for many drivers in defined situations, they do not do so for all drivers in all circumstances.”

This is because the retroreflective performance of the material depends on several factors such as sign location, and can vary significantly. These factors are detailed below.

6.2.1 Entrance angle

This is the angle between the vehicle, the sign and the normal to the sign face. It is the angle of the sign relative to the vehicle when the driver is viewing the sign. Figure 6 below shows the situation. It is important to note that the entrance angle will vary as a vehicle approaches a sign. The more angled the sign is, the less light will be returned to the driver and the sign will appear dimmer.

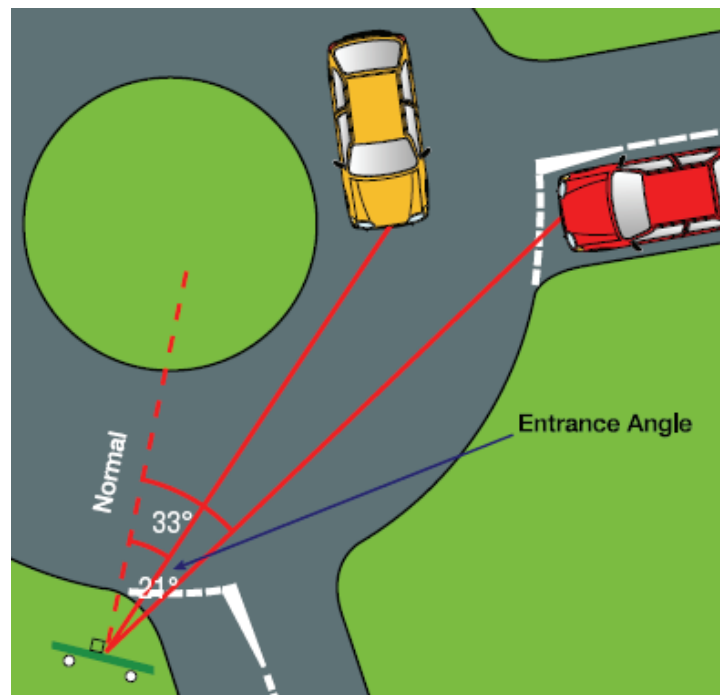

Figure 6 – The entrance angle (Courtesy of 3M (UK) Limited)

BS8408 specifies four entrance angle classes, as shown in Table 7 below.

Entrance angles	Class	Class description	Situation where this may occur
Up to 5°	A ₀	Straight	Overhead gantry
Up to 15°	A ₁	Narrow	Left/right verge sign on straight road
Up to 30°	A ₂	Medium	Right verge mounted sign on a curved road
Up to 40°	A ₃	Wide	Roundabout exit

Table 7 – Entrance angle classes specified in BS 8408

6.2.2 Observation angle

This is the angle between the driver, the vehicle headlights and the sign. When light illuminates the sign from the headlights, most of it is reflected straight back towards the source, so if the driver is sat far away from the headlights, not much of the light reaches his eyes. As Figure 7 below shows, car drivers sit fairly close to their lights, but lorry drivers sit a long way above them, and therefore are subject to a larger observation angle. This significantly reduces the performance of retroreflective signs for the drivers of large vehicles.

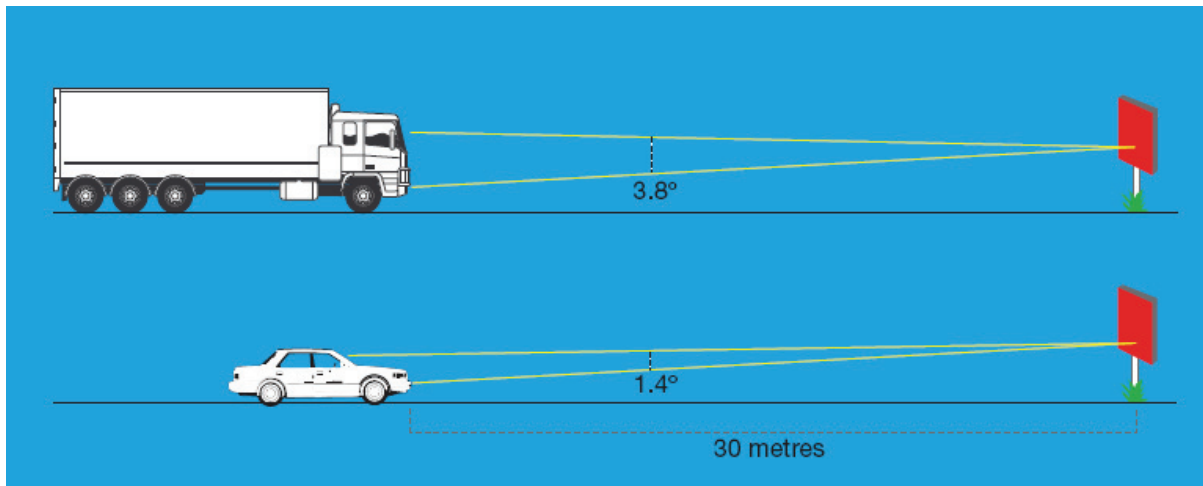

Figure 7 – Typical observation angles for cars and large vehicles (Courtesy of 3M (UK) Limited)

BS 8408 identifies two different vehicle types, shown in the table below.

Vehicle Class	Type of vehicle
V1	Cars
V2	Lorries

Table 8 – Vehicle classes specified in BS 8408

Motorcyclists sit very close to their headlights, and will therefore experience improved retroreflective performance over car drivers, so they can be treated as class V1. Van drivers are likely to experience similar performance to car drivers, depending on the size and type of van. For buses, the situation is quite variable. Many modern buses are quite low and have the driver sat nearer to the lights than would have been the case with older models. Buses are quoted as being in vehicle class V2 in BS 8408, although in reality bus drivers are likely to experience luminance levels somewhere between those given for classes V1 and V2.

6.2.3 Viewing distance

The speed of the road determines the range of distances from the location of a sign from which it will be viewed. The furthest distance represents the first chance a driver has to read the sign, while the closest distance gives the last opportunity to read it. On faster roads, signs will need to be viewed from further away and over a larger distance range in order to give the same reading time. This also helps determine the required 'x-height' (literally the height of the letter x) of the letters on sign legends – it is self-evident that signs viewed from further away need to have larger letters. Most signs dealt with in this report will be predominantly symbolic, and similarly symbols need to be larger if viewed from greater distances. The appropriate physical size of round and triangular signs in various applications is set out in the TSRGD (TSO, 2002).

With this in mind there are four specified distance subclasses in BS8408. Table 9 below shows these distance subclasses and the road speed they relate to.

Typical road speed (mph)	Recognition (symbolic) or legibility (legend) range	Distance Class
70	200 – 50 m	D1 (long)
60 – 70	200 – 50 m	D1 (long)
50 – 60	120 – 40 m	D2 (medium)
40 – 50	90 – 30 m	D3 (short)
30 – 40	90 – 30 m	D3 (short)
20 – 30	90 – 30 m	D3 (short)
20 – 30	50 – 20 m	D4 (close)

Table 9 – Road speeds and viewing range for signs in each distance subclass

6.2.4 Sign position

The position of a traffic sign affects how much light from the vehicle headlights falls upon it. This in turn affects how bright the sign appears to the driver. Signs positioned on the left verge receive the most light, while overhead signs receive the least. Four traffic sign positions have been defined, and these are shown in Figure 8 below.

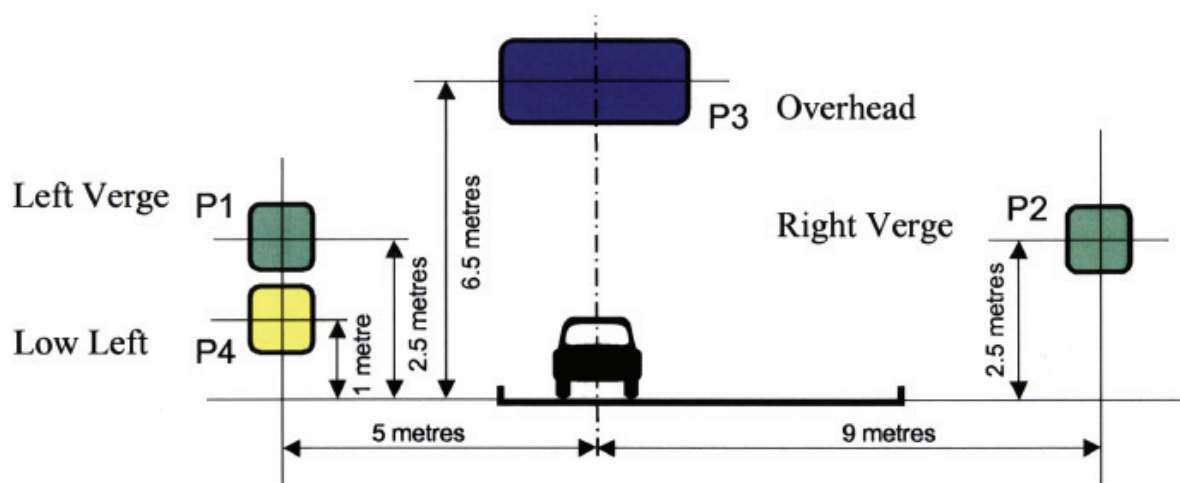

Figure 8 – The four positions traffic signs can be mounted in (Courtesy of 3M (UK) Limited)

Table 10 below, from BS 8408, shows the correction factors that must be applied to the performance index of signs not mounted in the left verge position for each vehicle type and distance class. This factor represents the difference in the amount of light from vehicle headlights that falls on the sign. For example, for a car (V1) travelling on a motorway, 46% of the light that reaches a left verge mounted sign will reach an overhead sign.

	D1 Motorway		D2 Primary roads		D3 Urban/rural		D4 Close viewed	
	V1	V2	V1	V2	V1	V2	V1	V2
P1 Left Verge	100%	100%	100%	100%	100%	100%	100%	100%
P2 Right Verge	73%	72%	73%	71%	64%	64%	50%	49%
P3 Overhead	46%	45%	51%	47%	39%	39%	36%	39%
P4 Low Left	275%	319%	798%	904%	992%	1379%	938%	1162%

Table 10 – Correction factors for the performance index of signs when mounted away from the left verge





6.3 Performance index tables from retroreflective material suppliers

Avery Dennison, Rennicks and 3M (UK) were all able to supply TRL with information on the performance index of their respective microprismatic material(s) for each category of vehicle, viewing distance and entrance angularity for signs mounted in each of the four positions. While the performance of each material varies slightly, all were found to give broadly similar performance and for the most part passed and failed the same signing scenarios. From the performance index table (Table 3 in Section 2.2) it is known that the required performance index in areas of street lighting is 1.0 for directional signs and 3.0 for regulatory and warning signs. The tables below indicate from the manufacturers' own data whether the materials meet this performance requirement for directional and regulatory/warning signs respectively.

6.3.1 Directional signs

The required performance index is 1.0 for directional signs, regardless of street light provision.

Key:

	None of the materials claim to meet the performance index requirement
	Some of the materials claim to meet the performance index requirement
	All of the materials claim to meet the performance index requirement
	Not relevant as this situation will never occur on the roads

Left verge mounted signs

























Distance subclass (D)	Entrance angle class					
	A1 Narrow		A2 Medium		A3 Wide	
	Car (V1)	Lorry (V2)	Car (V1)	Lorry (V2)	Car (V1)	Lorry (V2)
D1 Long						
D2 Medium						
D3 Short						
D4 Close						

Table 11 - Performance of retroreflective material on directional signs mounted in the left verge

Right verge mounted signs

Distance subclass (D)	Entrance angle class					
	A1 Narrow		A2 Medium		A3 Wide	
	Car (V1)	Lorry (V2)	Car (V1)	Lorry (V2)	Car (V1)	Lorry (V2)
D1 Long	Green	Red	Green	Red	Red	Red
D2 Medium	Green	Red	Green	Red	Red	Red
D3 Short	Green	Red	Green	Red	Red	Red
D4 Close	Red	Red	Red	Red	Red	Red

Table 12 - Performance of retroreflective material on directional signs mounted in the right verge**Overhead signs**

Distance subclass (D)	Entrance angle class					
	A1 Narrow		A2 Medium		A3 Wide	
	Car (V1)	Lorry (V2)	Car (V1)	Lorry (V2)	Car (V1)	Lorry (V2)
D1 Long	Green	Red	Grey	Grey	Grey	Grey
D2 Medium	Green	Red	Grey	Grey	Grey	Grey
D3 Short	Green	Red	Grey	Grey	Grey	Grey
D4 Close	Grey	Grey	Grey	Grey	Grey	Grey

Table 13 - Performance of retroreflective material on directional signs mounted overhead

Tables 10 to 12 show that for entrance angles up to class A2 (30 degrees), and at all distances except D4 (close), the retroreflective performance of the material for cars is sufficient to justify not lighting signs, using the criteria specified in BS 8408. For signs on the left verge, even at close distances, the performance threshold is satisfied in entrance angle class A1, and sometimes in A2. Most directional signs will be viewed within these allowed classes. On roundabouts the entrance angle may be larger than 30 degrees at some points along the path the vehicle takes towards the sign, but it will vary and should be at less than 30 degrees for a significant portion.

The performance for lorries is much poorer than for cars and none of the materials meet the performance requirement in any circumstances.

Schedule 17 of the TSRGD 2002 does not require any green (primary route) or white background (non – primary route) directional signs to be lit under in any circumstances, as they are not safety critical. On motorways, overhead signs require lighting, as do signs indicating the start and end of motorway regulations and approaches to motorways.

6.3.2 Regulatory and warning signs

The required performance index of regulatory and warning signs is 1.0 in an unlit area and 3.0 in an area of street lighting. The tables below show the materials assessed against the higher requirement, i.e. for areas of street lighting.

Key:

	None of the materials claim to meet the performance index requirement
	Some of the materials claim to meet the performance index requirement
	All of the materials claim to meet the performance index requirement
	Not relevant as this situation will never occur on the roads

Left verge mounted signs

Distance subclass (D)	Entrance angle class					
	A1 Narrow		A2 Medium		A3 Wide	
	Car (V1)	Lorry (V2)	Car (V1)	Lorry (V2)	Car (V1)	Lorry (V2)
D1 Long						
D2 Medium						
D3 Short						
D4 Close						

Table 14 – Performance of retroreflective material on regulatory/warning signs mounted in the left verge

Right verge mounted signs

Distance subclass (D)	Entrance angle class					
	A1 Narrow		A2 Medium		A3 Wide	
	Car (V1)	Lorry (V2)	Car (V1)	Lorry (V2)	Car (V1)	Lorry (V2)
D1 Long	**					
D2 Medium						
D3 Short	**					
D4 Close						

Table 15 - Performance of retroreflective material on regulatory/warning signs mounted in the right verge

**The only material that did not meet this requirement was rated at ~99% of the required value

Overhead signs

Distance subclass (D)	Entrance angle class					
	A1 Narrow		A2 Medium		A3 Wide	
	Car (V1)	Lorry (V2)	Car (V1)	Lorry (V2)	Car (V1)	Lorry (V2)
D1 Long						
D2 Medium						
D3 Short						
D4 Close						

Table 16 - Performance of retroreflective material on regulatory/warning signs mounted overhead

Regarding cars, for signs located on the left or right verge at entrance angle class A1 (up to 15 degrees), all of the materials either met the performance index or came within 1% of meeting it. The picture for entrance angle class A2 was more complicated, with all signs exceeding the performance index value for left verge signs at medium and short distances, while some met it for long distances, and none for close distances. For signs on the right verge, all materials exceeded the performance index value for the medium distance class, some did for the long distance class, and none did for either short or close distances.

For lorries, the performance index was not met by any of the materials in any of the scenarios.

For overhead signs, one material met the performance index value at a distance class of D2, but apart from this all materials did not meet the required value in any scenario for either type of vehicle.

6.4 Factors adversely affecting the retroreflective performance of signs

Geometrical considerations are not the only ones that dictate the performance of retroreflective materials. There are other environmental and man-made factors that can reduce the visual performance of retroreflective sign face material, and these are detailed below.

6.4.1 Dew formation

The formation of dew on traffic signs can cause a marked deterioration in their performance. The water on the surface of the sign distorts the path that light takes as it reaches the sign, and again as it is reflected back so that it does not reach the driver. As less of the incident light is returned to the driver, the sign appears to be dimmer and gives the appearance of being dirty. Consequently the luminance is significantly reduced. TRL have researched the effect of dew on the retroreflective performance of traffic signs, and found it to be a serious problem (Thompson *et al*, 2006a). Figure 9 below shows this effect on a directional sign.

Dew is most predominant on rural signs, although urban signs are by no means immune to this problem. In locations that require a high level of luminance, consideration should be given to applying dew resistant film to any signs which are intended to be unlit (Thompson *et al*, 2006b).



Figure 9 – The same sign photographed at night using the camera flash, in the presence (left) and absence (right) of dew

6.4.2 Dirt

Dirt and grime are not reflective and so a dirty sign will perform less well than a clean one. How quickly a sign gets dirty varies from site to site and depends on the exact location of the sign. Generally signs in rural areas are more likely to become dirty, and signs located near trees are more inclined to suffer from algae growing on them. Figure 10 below shows algae on a warning sign in daytime conditions.



Figure 10 – Algae on a warning sign, reducing conspicuity by both day and night

6.4.3 Graffiti

In certain urban areas graffiti can be a large problem. This can be both in the form of spray graffiti and stickers being attached to a sign face. Figure 11 demonstrates both types of graffiti. Graffiti can render signs completely useless and needs to be removed from sign faces in order for them to be effective in both daytime and night-time conditions. However, care needs to be taken when removing graffiti, as the retroreflective material on the sign face can easily become damaged, as shown in Figure 12. It may be considered prudent to invest in graffiti protective overlay film for signs in especially vulnerable locations, especially if they are to be unlit. For more information on graffiti resistant film see Thompson *et al.*, (2006b).

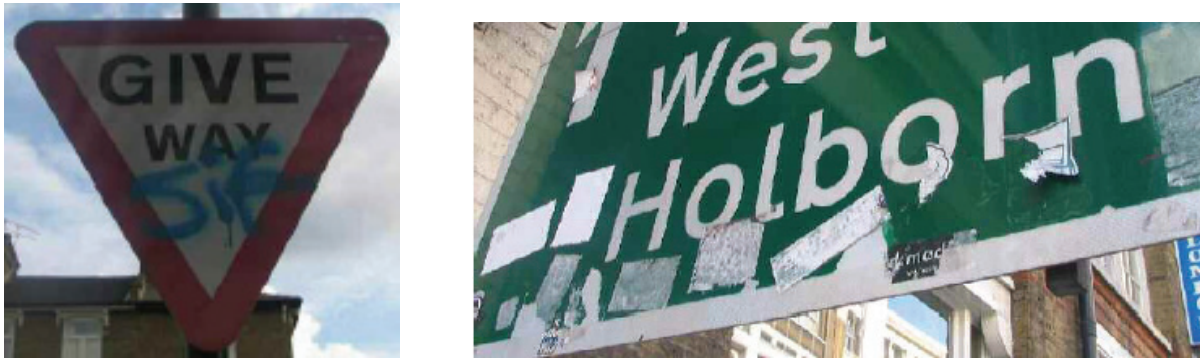

Figure 11 – Spray graffiti (left) and sticker graffiti (right) can both detract from a signs' message



Figure 12 – Removal of graffiti can damage the retroreflective surface of signs

6.4.4 Street lighting

There are two factors to be taken into account when considering the observation of traffic signs. Conspicuity is a measure of how the sign stands out against the background and determines how likely it is to be seen. Legibility determines how easy it is to read the detail on the sign.

For directional signs, legibility is dominant factor as the signs need to be read at the detail of individual letters. Many of these are also quite large and so naturally quite conspicuous. Most regulatory and warning signs are symbolic and fairly small. For these signs, conspicuity is the dominant requirement as once they are seen the symbol will be easily recognised and understood. The performance requirement for warning and regulatory signs is higher in areas of street lighting. This is because signs will stand out from the background less when the background luminance level is higher. Increases in the quality of street lighting mean that distinguishing colours at night is less of a problem under modern lights, and accordingly once a sign is observed it will be more legible. However, increased background luminance from better quality lighting reduces the conspicuity of signs and therefore the chance that they will be seen at all.

6.5 Summary and conclusions

As directional signs on local authority roads do not require lighting under current regulations, analysis of potential situations to remove lighting from signs has focussed on regulatory and warning signs.

The performance of retroreflective material varies significantly between different driving scenarios and depends on the geometry of the road, the location of the sign and the type of vehicle being driven in any particular situation. As a result it is quite difficult to make generalisations about the

performance of these materials, and when they will provide equivalent or similar illumination to direct lighting, but nonetheless some conclusions can be drawn from the available data.

For drivers of large vehicles in class V2, retroreflectivity alone will never provide a similar level of luminance to direct lighting. In situations where the needs of lorry drivers are to be taken into account, safety critical signs will continue to need direct lighting. Opportunities for reducing the lighting requirements will therefore only be found when the performance for large vehicles is not important, and it is not entirely clear when, if ever, this will be the case. BS 8408 specifies only that if the percentage of lorries is 'low' then the vehicle class V1 may be used to determine whether a sign needs lighting; a view needs to be taken on what the appropriate percentage figure is for this. DfT consider safety above all other considerations and so in most situations would take large vehicle needs into account. It was stated that for residential streets the performance for large vehicles may not be relevant, and consideration might be given to ignoring the needs of large vehicles in such streets, but the number of signs in residential streets is fairly low, so this is not a significant gain.

In London, a lorry ban is in force at night on many roads, and this may offer a situation in which a relaxation in the current sign lighting requirements could be considered. However the ban does not commence until 9pm, which in winter time in several hours after the fall of darkness. Furthermore, the ban only applies to vehicles over 18 Tonnes, which may not include all lorries large enough to be considered as being in class V2. Nonetheless, this highlights that there may be potential situations where a relaxation is a realistic possibility.

For any situations where it is in future agreed that vehicle class V1 may be used, then using the performance index in BS 8408 as a guide there is certainly a case for relaxing the lighting requirement in certain situations. This would apply to signs mounted on the left verge at entrance angles of less than 30 degrees, except for those viewed at especially close distances, in distance subclass D4. It is difficult to envisage a situation where a sign viewed from within the longest distance class D1 will be at an angle of over 15 degrees so the fact that not all materials meet the performance requirement for long distances in angle class A2 may not be a barrier. In the case of right verge mounted signs then the same applies to signs with entrance angles up to 15 degrees. In order for this to be a realistic proposition, it would first be necessary to carry out very detailed research and measure the performance of signs in a wide range of driving scenarios.

In summary, the authors cannot currently recommend that the lighting requirements for signs are relaxed, as the performance of retroreflective materials is not sufficient for large vehicles to justify it, and it is unclear when their needs can be ignored. Data from retroreflective sign material manufacturers indicates that there may be some specific circumstances in which direct lighting may not be necessary, but a further study measuring the performance of these materials for a range of vehicles and a range of circumstances, carried out with approval and input from DfT would be required to establish this for certain.

If lighting is to be removed from any traffic signs so that they rely solely on their retroreflective performance, then it is of increased importance that they be subject to regular maintenance to ensure that they are clean, correctly angled and that the retroreflective surface is undamaged. Dew protective film should also be considered for signs in locations that are vulnerable to the formation of dew, likely to be predominantly those in more rural locations.

7 Work Package 6: Practical advice on the use of various types of traffic signs and bollards

7.1 Introduction

Retroreflective material provides a comparable level of illumination to direct lighting in many circumstances, but it cannot by itself provide sufficient illumination to justify the removal of all lighting of bollards and signs. As highlighted in the previous section, retroreflectivity alone does not provide equivalent illumination to direct lighting for drivers of large vehicles in any circumstances, except when a sign/bollard is mounted in a low position. Consideration therefore needs to be given to alternative methods of lighting for these situations where it will still be required. To this end consultation has taken place with manufacturers and users of alternative products to the standard types of sign luminaires and lit bollards. This section presents a review of viable options for the lighting of traffic signs and traffic bollards, and in the case of traffic bollards, discusses the use of unlit retroreflective bollards.

7.2 Traffic signs – introduction

Although lighting may be required for many traffic signs, this does not mean that there is no potential for energy and cost savings. Standard fluorescent tube luminaires can now be replaced with LED lighting, which reduces the energy consumed and the number of maintenance visits to change the lamps. Solar powered sign lights may be considered as a practical alternative to using mains power, especially in situations where electrical connections and cabling are not yet installed. Electroluminescent signs offer both improved performance and reduced power consumption over traditional sign lighting. All are considered further below.

7.3 Using LEDs as the light source instead of standard luminaires

LEDs potentially offer energy savings (and therefore cost savings) and a vastly improved lifespan compared with conventional luminaires, thus reducing maintenance requirements. For these reasons, much research has been undertaken into LEDs in recent years and they are now a realistic alternative. Unlike standard luminaires which stop working suddenly and entirely, LED's fail over time by gradually getting dimmer. The lamp life quoted is usually when the LED is performing at 60 – 70% of its initial light output, so another potential advantage is that even after 'failure' the LEDs still provide some light on the sign face.

7.4 Solar powered signs

As highlighted in the project brief, the installation of electrical connections and cabling to traffic signs can be a significant upfront cost. This process can also add long delays to completing the installation of traffic signs and bollards. These facts, coupled with the increasing cost of mains electricity make solar powered signs a very attractive proposition. A solar panel and control equipment can quickly be installed on an existing sign post. Once installed, the solar panel provides free electricity. Whilst a wide range of vehicle-activated signs are solar powered, at this time there are very few solar powered external lights for signs. It is only with the increasing efficiency of LED lighting, and of solar panels themselves that it has become feasible to light signs in this way.

Solagen supply (and fit if required) solar lighting units onto existing signposts. They are currently suitable for 650mm and 750mm round or triangular signs, but the company have stated that they could easily develop a system for larger signs if there was market demand to justify it. The company have stated that installation should only take 30 minutes, and a copy of the installation manual is attached in Appendix D. Once installed the maintenance of these signs is minimal. The battery requires

changing at between seven and eight year frequencies, while the LEDs should last over 20 years and the solar panel at least 40 years. Figure 13 below shows a Solagen sign at the roadside.



Figure 13 – A traffic sign with solar powered lighting (courtesy of Solagen Ltd)

7.5 Electroluminescent signs

Electroluminescent signs are a type of internally illuminated sign, lit from within by a thin electroluminescent sheet. This is built into the sign face and fits between the metal sign backing and the retroreflective sheeting on the front. The retroreflective sheeting is translucent to allow the light to pass through it. The photocell and electronics are all contained in a sealed unit which can be mounted inside the sign pole. The sign therefore has the same appearance as an unlit sign and there are no external lighting elements or wires at risk of being damaged, potentially saving on both nuisance vandalism and the danger of having electrical connections exposed. Installation is relatively simple and a guide is in Appendix D. Figure 14 below shows both the composition and appearance of an electroluminescent sign.

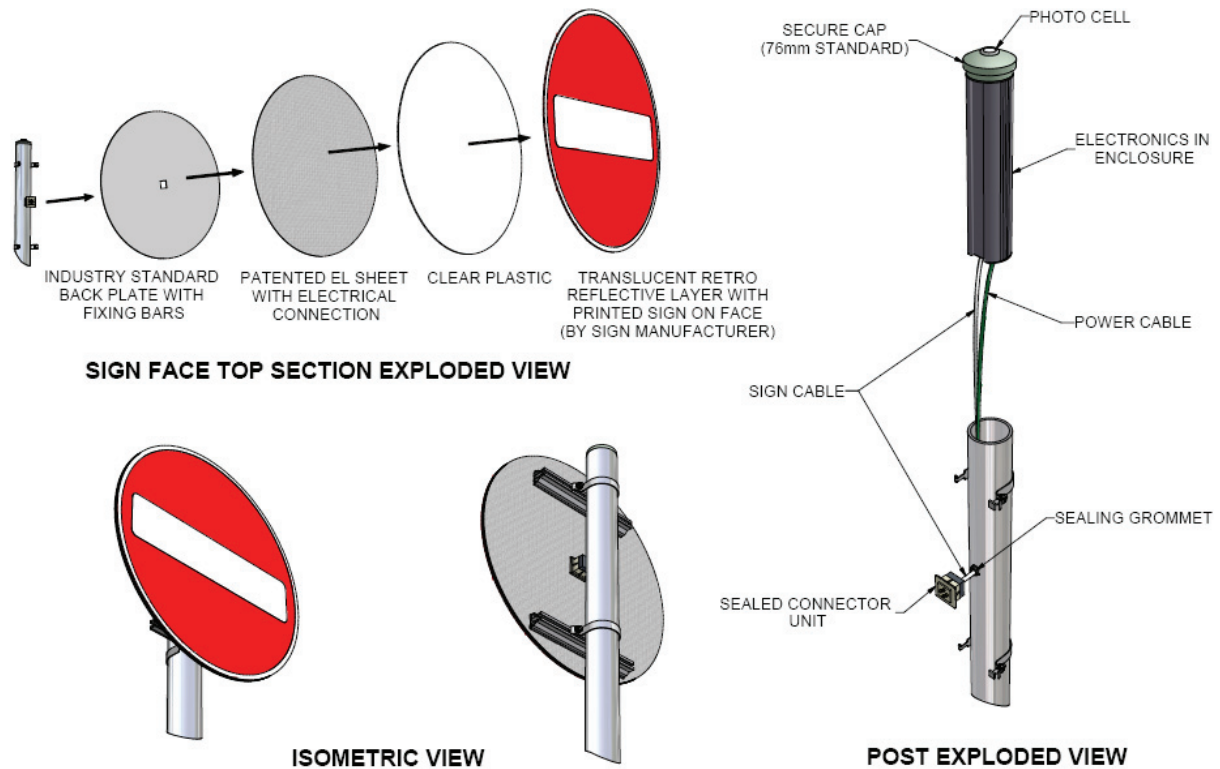

Figure 14 – Composition (top and right) and appearance (bottom) of an electroluminescent sign (diagram courtesy of One2see signs Ltd)

A key feature of electroluminescent signs is the uniformity of light across the sign face which makes them more conspicuous than the normal type of illuminated signs – they are clearer to read, can be seen up to three times further away and can be observed from greater entrance angles, as demonstrated in Figure 15 below.

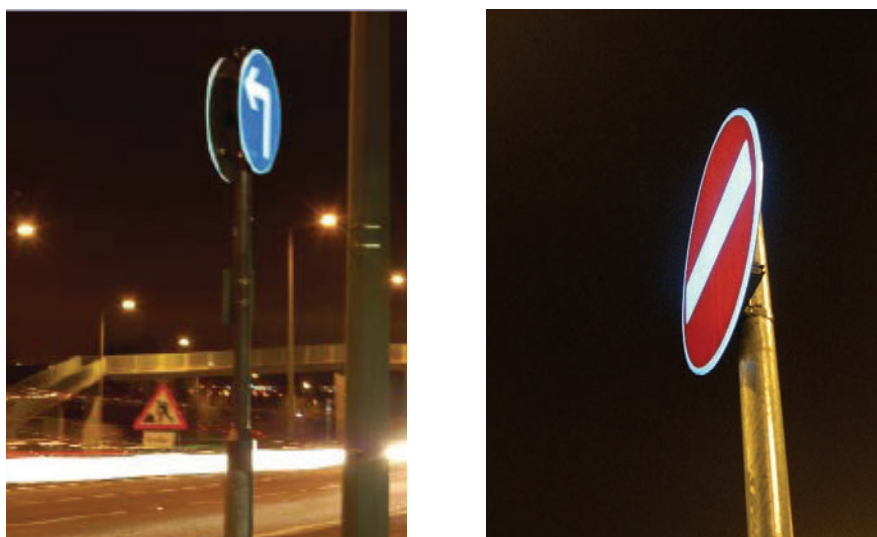

Figure 15 – Electroluminescent signs lit up at night (courtesy of One2see signs Ltd)

As well as the above benefits in terms of safety, there are also potential energy and cost savings. One2see Ltd's signs currently operate at 15W, in comparison with standard lamps which operate at around 25W (Howard 2007). Furthermore, the lifetime of the electroluminescent material is ten years and during that time no bulb changes or other maintenance should be required, other than possibly sign cleaning. As light comes from within the sign there is also no light pollution. One drawback of this sign is that when the electroluminescent sheet stops working, the whole sign has to be replaced.

Research is currently continuing into this type of sign, and it is expected that within the next year a model that runs on 6W of power may be available. If this can be achieved then there is the potential to power this type of sign by solar energy, or even kinetic energy produced by vibrations from vehicles driving over the road. This would then also realise the cost benefits of not requiring electrical mains connections, as outlined in Section 7.4 above. Another potential future benefit is the ability to vary the luminance output of the sign. In line with DfT recommendations, the signs currently output the minimum luminance required of 10 candelas per square metre, but there is the potential for this to be increased slightly depending on background luminance levels.

7.6 Traffic bollards – introduction

Traffic bollards are in wide use on roads in the UK. They are used to indicate hazards, and define the safe route around them. These are most often in the form of islands in the centre of the road whether at roundabouts, side road junctions or islands installed on urban roads used for both traffic calming and to aid pedestrians crossing. Figure 16 below shows lit bollards forming a traffic island in the centre of the road.



Figure 16 – Bollards used in combination with a D610 ‘keep left’ arrow to form a traffic island

7.7 Traffic bollards – introduction

The standard types of internally lit bollard are a familiar feature on the roads and until recently were the only option available. One of the chief advantages of these bollards is the uniformity of light across the whole bollard, and the fact it is cast equally in all directions. This means that as well as being visible from long distances the bollard can be seen from any entrance angle, particularly useful in situations where this may vary significantly, such as at roundabouts. They have developed over the years and if installed correctly will now often survive impacts from vehicles and remain functional. If the bollard sustains damage and becomes deformed in shape then it can still operate to some extent. In

the event of a severe impact which shears the bollard from the base completely, the baselight will still be operational and perform a similar function to a cat's eye. Figure 17 below shows lit bollards on the approach to, and in the centre of, a roundabout.



Figure 17 – Lit bollards can be seen clearly from any angle and at long distances (note the lights on the road in the far background of this picture are from distant bollards)

Due to the large number of bollards in use on the UK road network, the cost of lighting them is significant. It is assumed that most bollards are group switched, so that they illuminate only after the hours of darkness. For any bollards that are not switched already, consideration should immediately be given to doing so. Low voltage lighting systems are now available, reducing installation time, installation cost, energy usage and increasing safety. Simmons signs offer such a system, which can be sited adjacent to an existing 240V connection. Low voltage cable can then be run to the bollard sites, involving slitting rather than excavation, and consequently saving on installation time and cost. Up to nine 11W lamps can be powered by one of these systems.

Due to electricity costs, unlit bollards are an attractive proposition. There are already some specific situations where lighting is not required for bollards and in these circumstances retroreflective bollards may be used instead. Where lighting is still required, solar powered bollards may be considered for use.

It is important to stress that bollards provide a very valuable contribution to road safety, and where road hazards exist it is important that these are clearly visible by both day and night through the use of bollards. Nonetheless it is worth considering whether there are any circumstances in which bollards can be removed altogether, through the removal of any unnecessary road islands (those not used by pedestrians) or other situations such as pinch points where they are used for traffic calming purposes.

7.8 Retroreflective self-righting bollard (RSRB)

Retroreflective self-righting bollards are increasingly used as an alternative to lit bollards. These do not require any power and so reduce CO₂ emissions as well as running costs. When installed at new sites they also negate the need for electric cabling, offering a significant saving both in time and money. As they are mounted in a low position and a large amount of light from the vehicle headlights

falls upon them, they can provide a high level of illumination from retroreflectivity alone (Refer to Table 9 in Section 6.2.4 for an indication of just how much). Mounted on a spring, they are self-righting and in many circumstances will return to their original position after impact with a vehicle. They are available both single and double sided. Figure 18 below shows a retroreflective bollard.



Figure 18 – A retroreflective bollard (Photo courtesy of TMP Limited)

The circumstances in which they are permitted to be used are outlined in Section 2.4.

Installation of these bollards is simple and an instruction manual has been provided by TMP, again found in Appendix A. The expected lifetime of these bollards is dictated by that of the retroreflective material, and is approximately 10 – 12 years.

As these bollards rely on their retroreflective sign faces for illumination, these will need to be kept clean in order for the bollard to function correctly. For the same reason, to maintain usefulness it is also imperative that the bollard does not become significantly twisted after impact, and that the retroreflective sheeting is not significantly damaged. If either of these occurs then the bollard will require maintenance or replacement. In the event of a severe accident which shears the bollard from the base no illumination will be provided so urgent repair will be required. TMP have stated that in most situations where the bollard is damaged it is salvageable and full replacement is not required. For example, in a shearing accident, replacement of the spring, costing about £30 – 40 may be all that would be required. TMP bollards can only at present be supplied with protective anti graffiti/anti fly sticker film, but there is no reason why dew resistant film could not be used with the bollards – TMP stated the reason they aren't currently supplied with it is because no problem with dew has yet been identified.

A leading manufacturer of both traditional lit bollards and RSRBs has expressed concern about the widespread use of RSRBs. Bollards are by nature located in positions vulnerable to vehicular impact, and being mounted in a low position are also highly likely to accumulate pollutants, dirt, salt and grit on the face, as well as being vulnerable to vandal attack and graffiti. In the case of an accident or person damaging the face or it being covered with dirt or graffiti, the level of illumination of an unlit bollard will be significantly reduced, and if completely removed from its foundations there will be no illumination at all. Meanwhile standard lit bollards will also often withstand vehicular override and return to their original position, and even if marked with tyre marks or scratches and dented from such an incident the performance will be almost entirely unaffected. Dirt will, of course, also reduce the performance of lit bollards, but to a lesser extent. Figure 19 below shows retroreflective bollards on a traffic island when newly installed, and less than a month later, when they have been covered with dirt.



Figure 19 – Retroreflective bollards shown when newly installed (left) and less than a month later (right), at the same location (Photos courtesy of Simmonsigns Ltd)

At existing sites where the required electrical infrastructure for lit bollards is already in place, the cost savings from installation of RSRBs may be fairly small. This is due to the upfront costs of RSRBs being significantly higher than the standard lit bollard but also the added cost of making safe the electrical connection.

7.9 Solar powered retroreflective self-righting Bollards (RSRBs)

Given the limited situations where unlit bollards are authorised for use, solar powered bollards have very recently become available. These combine retroreflective sign face material with LED lighting for the regulatory sign symbol. The same benefits are realised as for the unlit bollard in terms of energy usage and cabling requirements, but with the additional benefit that DfT authorise their use in any location. Figure 20 below shows a solar powered bollard.

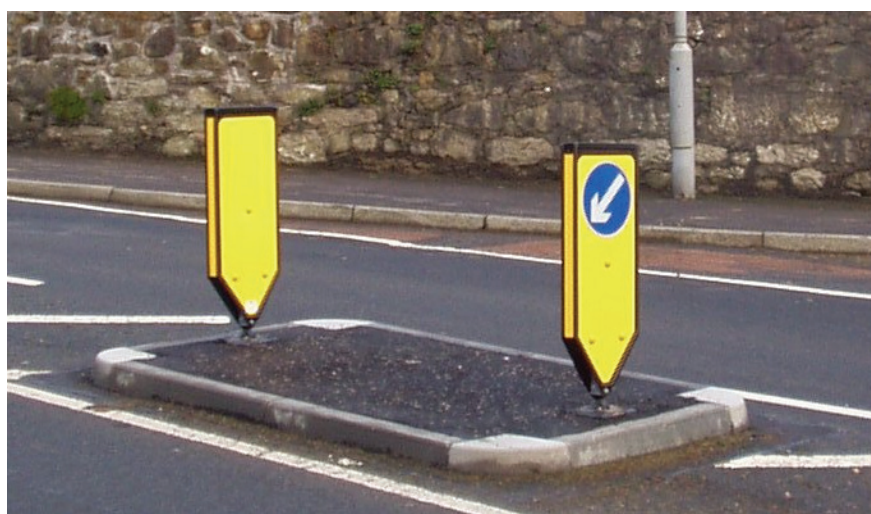

Figure 20 – Solar powered bollards (Photo courtesy of TMP Limited)

Except for the retroreflective material, most parts are replaceable in case of damage from a vehicle. The bollard is highly vandal proof and in testing one bollard was still capable of illuminating after being driven over 12 times. The life of the battery is about 6 – 7 years and it is suggested that it be changed after 5. The LEDs have an expected lifetime of 15 years. The life expectancy of the whole product is again limited to 10 – 12 years by the lifetime of the retroreflective material. Installation is exactly the same as for the other types of unlit bollard. Appendix A contains a TMP installation guide.

These bollards are only available single sided at present and the same maintenance requirements apply in order for them to remain useful. The solar panel will need to be kept clean enough to function, and the retroreflective material needs to be kept clean. A bollard pointing in the wrong direction will be of little or no use as the retroreflective material and light are only on one side. Again, if sheared completely from the base, there will be no source of illumination warning drivers of the hazard.

Some of the same concerns exist for solar powered bollards as for unlit RSRBs. Only a relatively small part of the bollard is illuminated and the rest of the sign face relies again purely on retroreflectivity. The level of illumination is smaller than for standard lit bollards and it is assumed this may affect the viewing distance. Nonetheless this bollard is sufficiently illuminated such that it meets DfT's requirements for lighting.

In order to use solar powered bollards, authorisation will be required from DfT. The process is the same as for unlit RSRBs, and each council wishing to use them will have to apply individually as outlined in Appendix A.

7.10 Application of The Construction (Design and Management) Regulations 2007

The Construction (Design and Management) Regulations, 2007 (or CDM, 2007) apply in relation to any construction work undertaken, which self-evidently includes all traffic sign and traffic bollard installations. The purpose of the regulations is to ensure a safe working environment for contractors, and that the presence of the construction site does not offer a significant hazard to pedestrians, road users or anybody else.

When designing traffic management schemes, particularly those involving traffic island installations in the centre of the road, consideration needs to be given to Part 2, item 11 (Duties of designers) paragraph 3 of these regulations, an extract of which is given below:

“Every designer shall in preparing or modifying a design which may be used in construction work in Great Britain avoid foreseeable risks to the health and safety of any person —

- (a) carrying out construction work;
- (b) liable to be affected by such construction work;
- (c) cleaning any window or any transparent or translucent wall, ceiling or roof in or on a structure;
- (d) maintaining the permanent fixtures and fittings of a structure...” (TSO, 2007a)

Many traffic islands located in the centre of the road are difficult to maintain safely due to the lack of working space. Figure 16 above shows a typical example, where vehicles travel in very close proximity to the island. One lane of the road can be closed, but this still requires very close working to live traffic. Obtaining a road closure order typically costs in the region of £1000 and requires a minimum of six weeks notice. This is not a realistic proposition for the multitude of bollard sites located in the centre of roads. It can be argued that these sites are unsafe to maintain and that therefore part (d) above is not being fully adhered to.

7.11 Pre- installation requirements and considerations

Before installing new traffic signs and bollards a risk assessment should be undertaken. This should include assurance of appropriate arrangements for maintenance. In addition, in order to ensure best value, benefits of installing new traffic signs and bollards should be weighed up against the whole life costs.

7.12 Summary and conclusions

It is clear from study of retroreflective performance undertaken in Work Package 5 that the requirement to light signs and bollards in some circumstances will remain. This does not mean that there is no potential to save on costs, energy usage and carbon emissions however.

Through use of the latest LED lighting units for signs, energy consumption of standard externally and internally lit signs can be reduced. Bulb changes are also required to be carried out far less frequently for these lighting units.

Electroluminescent signs have potential benefits over traditionally lit signs in terms of safety, maintenance and energy usage and as these are still being improved may offer more in future. Solar powered signs offer free electricity without cabling, low maintenance requirements, and may prove especially useful in situations where installing electrical cables is difficult.

As stated by DfT during the consultation, it is always worthwhile considering whether a sign adds value, as one of the easiest ways to save money on sign lighting is to remove those signs that are unnecessary.

The use of unlit and solar powered RSRB bollards should be encouraged in the appropriate circumstances. They require no electricity supply and offer long term savings in energy and cost. Care needs to be exercised when choosing sites in which to use these however. Standard bollards are visible from long distances and any entrance angle, due to the high level and equal spread of light throughout the bollard. Both solar and unlit RSRBs provide illumination in only one direction – that which they are facing. Any advantages gained from the illumination of the surroundings by standard bollards, such as displaying the presence of pedestrians will also be lost. Furthermore a strict inspection and maintenance regime will be required to keep them clean and ensure they are undamaged, and damaged RSRBs need to be replaced quickly.

As for traffic signs, it may be considered worthwhile to review the use of bollards and consider the necessity of centre islands or pinch points used primarily for traffic calming which then require installation of bollards and have ongoing maintenance costs. Concerns have been raised about how maintenance of these sites can be unsafe, and not in accordance with the principles of the CDM, 2007, and this also needs to be taken into account.

By combining use of unlit bollards with solar powered sign lighting, it is possible to avoid the requirement for mains electricity in traffic management situations, potentially offering an upfront cost saving. This will be most useful for new sites, as at existing sites electrical cabling and connections will most likely already be installed. Figure 21 below shows a mains free traffic island.



Figure 21 – A traffic island installed without requiring mains electricity cabling and connection

8 Work Package 7: Cost benefit analysis

8.1 Introduction

The aim of this section of the study is to investigate the relationship between the whole life costs of different sign lighting options and the total benefit received. This extends to both fixed road side signs and lit / reflective bollards.

The scope of such a cost benefit analysis is clearly very limited. It will be assumed that all options have met the statutory requirements for safety. This moves the focus of the analysis into lower level metrics – Sign Density and Availability.

8.2 Methodology

This analysis was based on the output from the formal survey results, supplemented with data requests from a sample of industry suppliers and the results from a previous TfL study (Howard 2007).

In order to undertake any form of cost benefit analysis it is necessary to define three degrees of freedom:

- The options available
- The Cost (or Whole Life Cost (WLC)) of each option
- The Measures of Performance (MoP) or Measures of Effect (MoE) of each option

8.2.1 Option Definition

Cost Benefit Analysis is based on underlining the differences between expenditure options. It is therefore crucial to be clear on the specific options to be considered. For the purpose of this study 3 main options were identified.

1. Fully Unlit
 - 1.1. Replace all lit signs with unlit retro reflective signs
 - 1.2. Replace all lit bollards with retro reflective bollards
2. Fully Lit
 - 2.1. Replace all unlit signs with lit signs
 - 2.2. Replace all retro reflective bollards with lit bollards
3. Technology Refresh

These options involve a level of generification. Rather than examining specific technical solutions this analysis aims to quantitatively compare the broad options.

8.2.2 Cost Data

The identification and acquisition of cost data is often surprisingly complex, usually more so than the performance data. This is due to a range of factors, for example:

- Transparency of finances
- Variable market conditions
- Confidentiality
- Material sourcing options

- Unforeseeable incidents

The primary source of cost data for this study is the output from work package 3. This identifies the cost figures provided by the survey recipients. It is evident that the values vary dramatically across the different returns due to the complexity in returning a definitive cost value. The sourcing of traffic signs and bollards is handled differently by different local authorities, most of which will involve one or more highways contractors to put in place (and possibly maintain) schemes that include signage. This results in a lack of transparency in the cost data and the resulting variance in survey returns. In order to temper these results, data provided directly by sign and bollard suppliers, sourced from materials' suppliers, was used to help define a representative value that could be used in the analysis.

Whilst it is possible to put a price tag on purchasing a piece of equipment, it is also necessary to take account of all the other costs associated with it (maintenance, replacement, installation etc) which leads to the concept of Whole Life Costs. These represent an attempt to incorporate the entire expenditure for the complete lifecycle of the equipment into a single lifetime figure. The R&D and material manufacture costs are straightforward to acquire. The costs for putting signs in place, lighting and maintaining them and, eventually, disposing of them, are more difficult to identify. This is simplified by prior research (Howard 2007) that examined a range of factors in detail including installation, energy usage, maintenance and replacement.

8.2.3 MoPs and MoEs

In order to undertake Cost Benefit Analysis it is necessary to define a measure that can be used to represent the benefit of each option. This is done by assessing the validity of the various Measures of Performance (MoP) available and combining them to produce a Measure of Effect (MoE) that represents a balanced and auditable quantification of the benefit. The MoP to MoE mapping used for this study is shown in Figure 22 below:

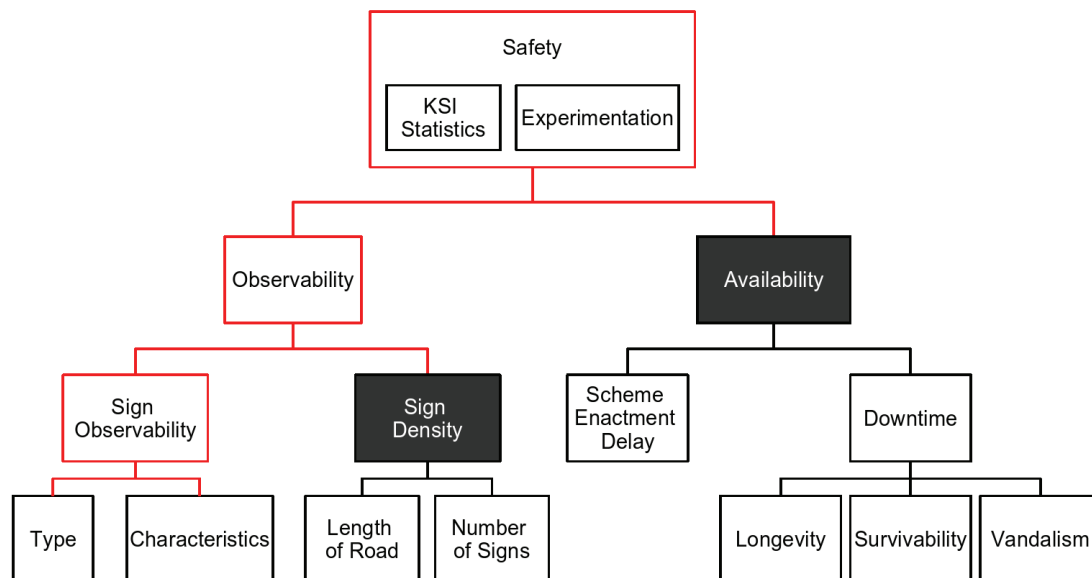

Figure 22 - MoP to MoE Mapping

The above figure shows the MoP to MoE mapping; with the top two rows containing MoEs and the bottom two rows containing MoPs. It has been colour coded; the overall structure shows the idealised study design, while the links highlighted in red are those that are either clearly practically unachievable or have been found, numerically, to be beyond the scope of this study.

The optimum MoEs would be those that directly reflect safety as this is the end goal of effective roadside lighting. Two types of metric that could provide this present themselves; real world statistics and experimental results.

Experimental results are limited. Those that have been undertaken are limited to synthetic trials rather than experiments out on the highway (this is a result of the risk to life from any such trials). There is some evidence to indicate road user compliance for the different signs but the output is not consistent and so unusable for comparing differing sign lighting solutions.

Real world statistics, captured from the STATS19 database, would provide an ideal source for determining the impact of sign lighting on accidents. Unfortunately this dataset only includes information about roadside lighting, not sign lighting, and so a direct comparison will not be possible. In spite of this killed and seriously injured (KSI) data was analysed to establish a relationship with roadside sign lighting density.

Due to these limitations it was not possible to base the entire Cost Benefits Analysis on the high level MoE of Safety. Instead it was necessary to focus on lower level measures. Figure 22 shows the chosen metrics (the boxes filled in black); Sign Density and Availability.

Sign Density: Using the data collected from the TRL Local Authority survey it is possible to determine how many lit signs and bollards each authority have deployed. This can then be interpreted in terms of lit signs and bollards per kilometre.

Availability: This metric is based on the inverse of the duration for which signage instructions are unavailable to road users. It is dependant on the time taken to put the signage in place and the total downtime of the signage due to a range of factors. While a more sophisticated option may have better performance characteristics it may in effect have greater downtime as a result of its sophistication. The metric is calculated using the following formula:

$$Availability = \frac{1}{Total_Scheme_Delay_Per_Year + Total_Downtime_Per_Year}$$

The value for total scheme delay was obtained from the survey returns. The value for total scheme downtime was derived by taking the estimates of frequency of downtime events from Howard 2007 and combining them with an estimate for the impact of each event type.

These metrics can then be assessed against the cost of the various options to produce the cost benefit analysis.

8.2.4 Data Sources

8.2.4.1 Local Authority Survey

Section 4 of this report discussed the questionnaire results in some detail. For this analysis it is only necessary to highlight the useful data fields for the Cost Benefit Analysis:

- Length of Maintained Highway
- Cost per illuminated sign
- Cost per non-illuminated sign
- Cost per illuminated bollard
- Cost per non-illuminated bollard

- Delay to scheme from lighting
- Total budget for traffic signs and bollards
- Total number of illuminated signs
- Total number of illuminated bollards

8.2.4.2 *System Based WLC*

The aforementioned report (Howard 2007) is a thorough investigation of Whole Life Costs for traffic signs in London along with an assessment of the potential saving to be made from selecting different lighting options such as LED or electroluminescent. This report has been used to source generic WLC data for a range of different activities and factors:

- Replacement and removal costs for internally and externally illuminated signs and bollards
- Maintenance event frequency for different types of signs and bollards
- Maintenance costs for different types of signs and bollards
- Annual energy cost for lit sign versus electroluminescent sign and bollard versus LED bollard

8.2.4.3 *Supplier Specific*

Various road sign suppliers and manufacturers provided technical data and costs for their products to TRL. The costs proved to be of limited value for this analysis, as generally it was not possible to combine cost information in such a way as to generate a Whole Life Cost. Nor was it possible to extrapolate a meaningful MoP from the optical performance characteristics (this is because it would be unsuitable to compare the options in this manner as they had all been produced in accordance with UK specifications).

8.3 Results

Before moving into the main analysis it was necessary to produce unified values for certain variables based on the TRL questionnaire returns. In the first instance it would seem straightforward to take the mean value, however upon inspection it became clear that this would not suffice for all categories. When plotted as histograms there was evidence of different clusters of responses that could be attributed to different interpretations of the questions posed. It was therefore necessary to plot and assess the returns from each question to estimate a usable value.

8.3.1.1 *Cost per Unit - Signs*

Below in Figure 23 are plotted the histograms for the cost per unit sign of both illuminated and non-illuminated varieties, with cost on the x -axis and normalised frequency on the y -axis.

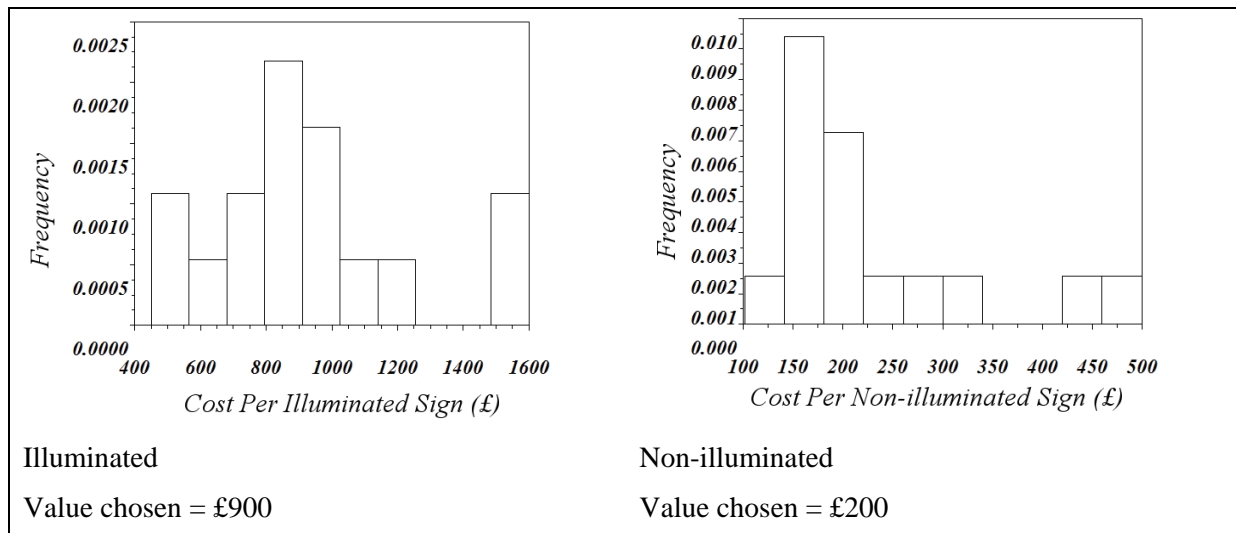

Figure 23 - Histograms of cost for illuminated and non-illuminated traffic signs

The range of costs displayed is high; from £450 to £1600 for illuminated signs and from £150 to £450 for non-illuminated. The actual cost of manufacturing and installing a sign should not vary so greatly – the materials are sourced at similar prices and they are constructed and installed with similar levels of effort. This wide range must be due to how the value has been arrived at, with different responders using different assumptions when producing their costs. Looking first at the figure for illuminated signs, there is a large cluster around the £900 mark and strong outliers at the high and low costs. This value is taken forward as the used cost as it is the approximate average of the most common interpretation of the question⁹. Similarly for the non-illuminated figure there is a strong cluster at the low end of the range with only two outliers in the top half of the range. As such the low cost cluster was taken as the used value.

8.3.1.2 Cost per Unit - Bollards

Below in Figure 24 are plotted the cost histograms for illuminated and non-illuminated traffic bollards.

⁹ It is not possible to determine the specifics of the interpretation as this could include a range of included or excluded factors in the responders costing calculations. A secondary reason for using the lower value is that the higher values may contain estimations of Whole Life Cost, a modification that is made later in the calculations presented here. It is therefore considered more even handed to err towards the lower value.

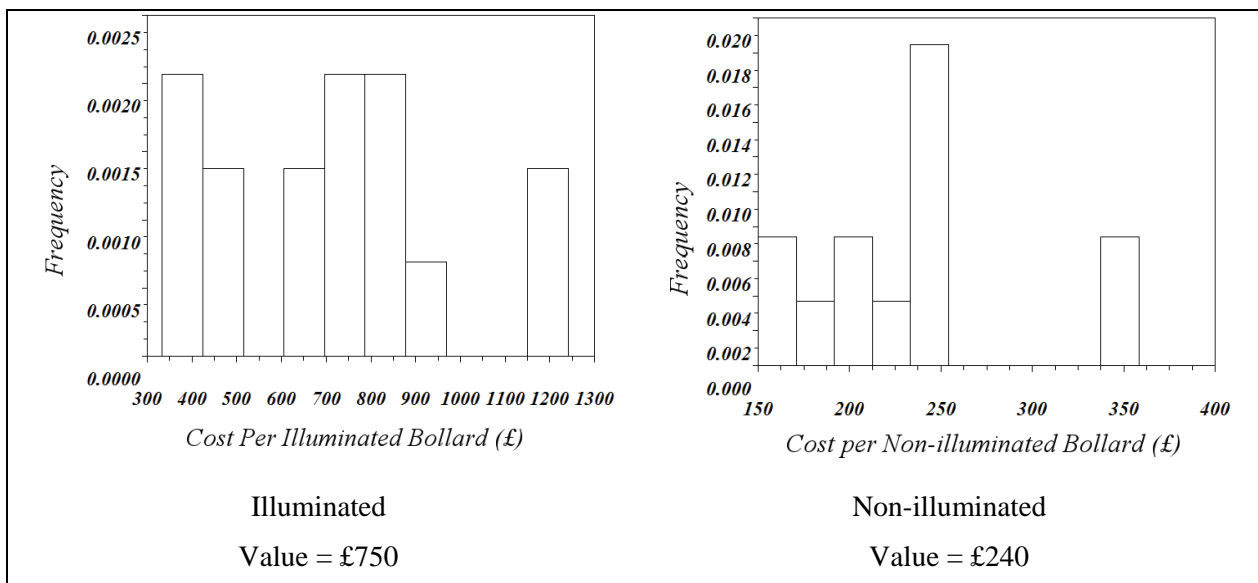

Figure 24 - Histograms of cost per illuminated and non-illuminated traffic bollards

In contrast to the results for costs of road signs, there is no clear distinction between the values provided by the responders. The data for illuminated bollards show a flat distribution and so the median value of £750 is chosen, while the responses for non-illuminated appear to cluster around a central value and so the mean value of £240 is used.

8.3.1.3 Scheme delay to install lighting

Shown in Figure 25 below is the histogram plotted of responses to the survey question asking how long road construction schemes are delayed by the requirement to install lighting for the signs, along with a secondary figure to aid with the interpretation.

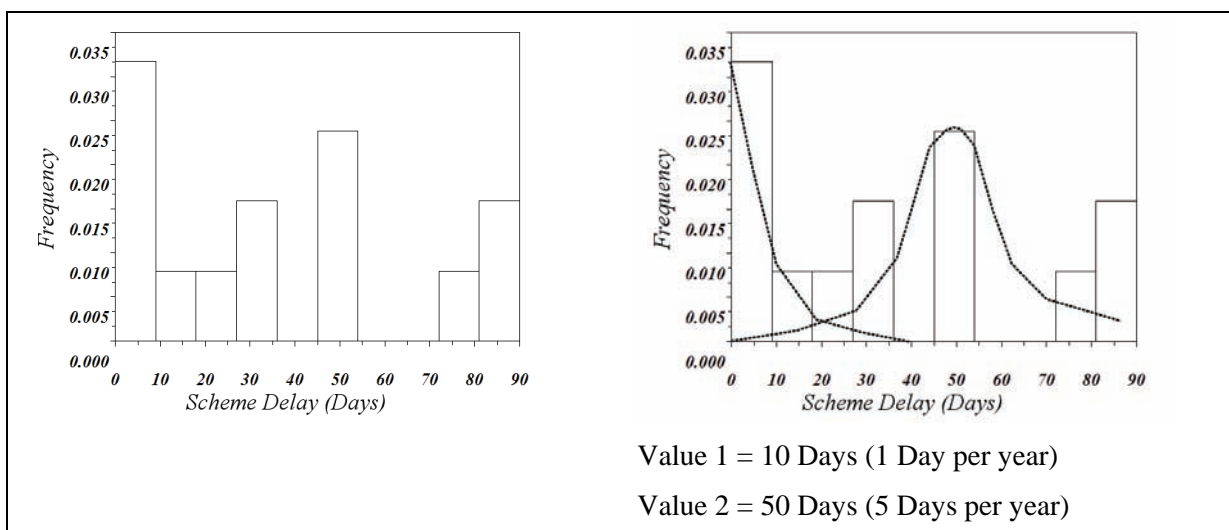

Figure 25 - A histogram of scheme delays resulting from installing sign lighting

For this value there is a broad range of responses from zero days, which clearly assumes that no additional effort is required to install sign lighting, up to responses of three months where it is perhaps assumed that mains electricity needs to be installed. In order to try to make sense of these results consider the right-hand image in Figure 25. Superimposed onto the histogram is one possible interpretation of the underlying behaviour. It is important to note that this is only a hypothesis and the evidence to support it is not strong. Nonetheless, it is intended to serve as a thinking aid for the problem. The curve that peaks as it approaches the delay equals zero represents responders who are assuming that the infrastructure to support the sign lighting is in place and will require only minimal effort to complete the setup. The curve that peaks at a delay of around 50 days is the responders who are assuming that significant additional work will be required to enable sign lighting such as laying down roadside infrastructure.

These two curves were used to estimate two different values for scheme delay, 10 days and 50 days. These are to be used side by side to compare the effect of variability in this factor on the main analysis.

8.3.1.4 Signs per kilometre

A histogram of the value of illuminated signs per kilometre is shown in Figure 26 below.

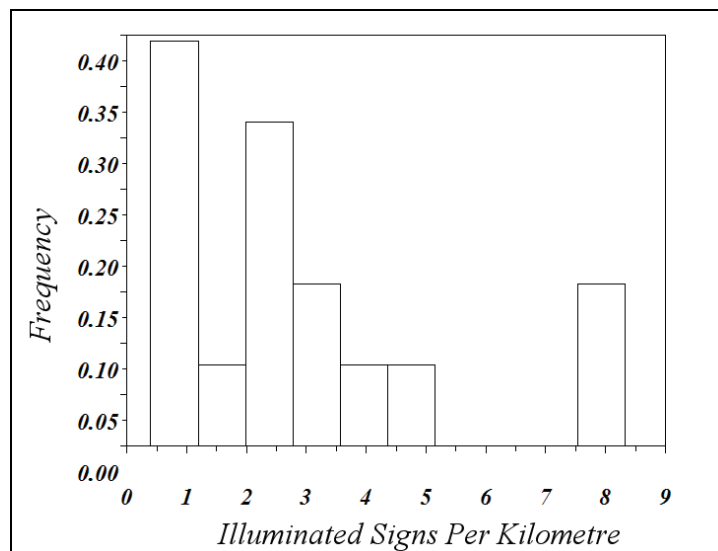

Figure 26 - A histogram of illuminated sign density in units of signs per kilometre

Based on the shape of the figure above it was not possible to draw out any meaningful conclusions. Unlike the other responses considered, this parameter is not dependant on interpretation and is instead a feature of the different local authorities surveyed. Hence it would not be reasonable to attempt to draw any conclusions from it. Instead the entire range of responses is considered in the analysis of sign density versus budget per kilometre.

8.3.1.5 Budget per kilometre

Shown below in Figure 27 is a histogram of the budget per kilometre values obtained from the survey.

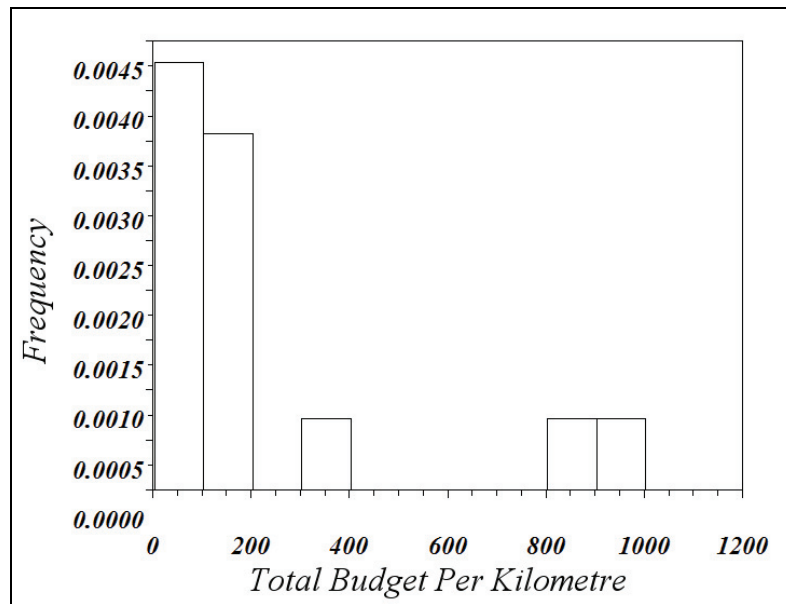

Figure 27 - A histogram of budget per kilometre of road

The significant property of this figure is the high concentration at lower values with two outliers at high values. Upon inspection this anomaly is quickly explained – these two outliers are the two London boroughs surveyed and as such will have a denser road network with high volumes of traffic to manage, so justifying the larger budgets per kilometre. As with the result for signs per kilometre, it is not necessary to draw out a single value as the whole range of values will be used.

8.3.1.6 Sign Density

The first of the two Measures of Performance to be examined is Sign Density. The aim of this is to investigate whether local authorities with higher budgets are more or less inclined to deploy electrically lit options. Instead of using the total budget and total number of lit signs, values per kilometre were used to partially counteract the effect of variation between areas (areas containing more road but with the same budget would actually have a lower budget per unit length of road). The results are shown in Figure 28.

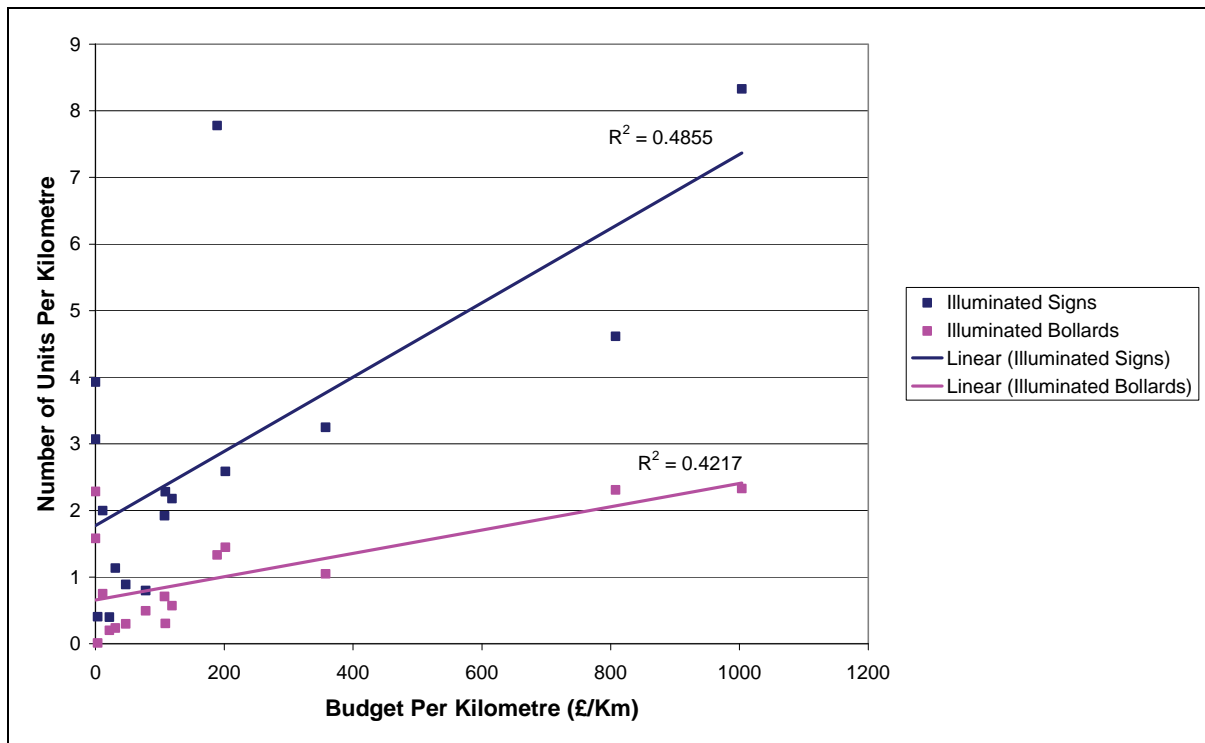

Figure 28 - A graph to show the lit sign and bollard density against the budget per unit kilometre

This figure, and the relatively high R^2 values, demonstrates that there is a relationship between the budget per kilometre and the number of lit signs or bollards per kilometre. Whilst only an empirical observation, it does support the notion that local authorities with more money to spend on road signage will tend to install more lit signs and bollards by preference. This is quite an indistinct conclusion as there is a wide array of different factors that can affect how the different authorities choose to spend their budgets.

In the methodology section the linkage from MoPs to MoEs was identified. It was considered that it might be possible to identify a relationship between sign lighting and the accident statistics from the STATS19 database. The revised MoP to MoE mapping is shown below in Figure 29.

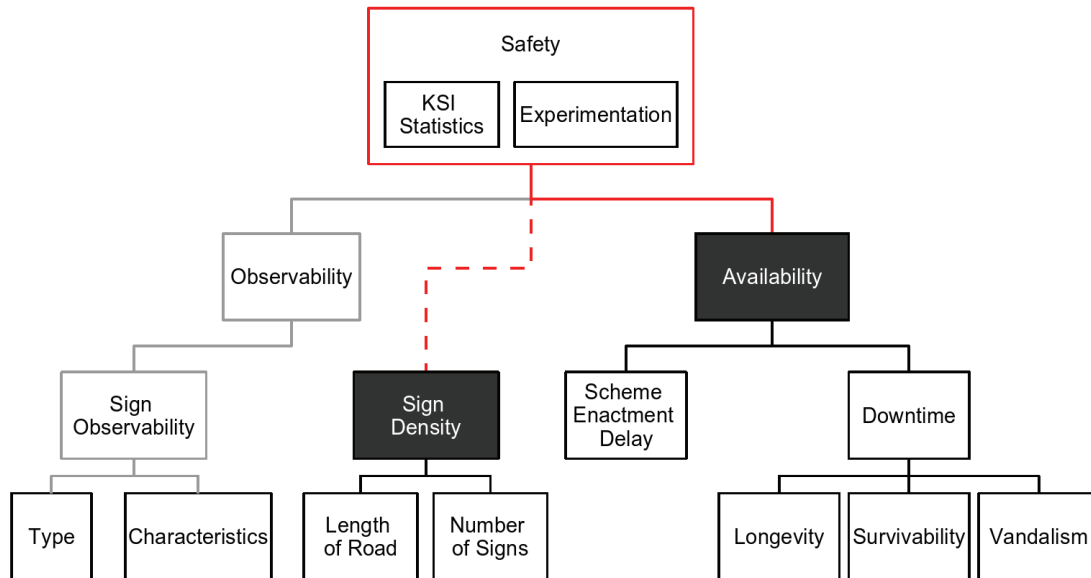

Figure 29 - Revised MoP to MoE linkage for Sign Density

The actual incident entries themselves do not contain any details on sign lighting, only on the general lighting conditions themselves. It was therefore only possible to directly compare lighting density against the KSI per capita (population) statistic which is shown in Figure 30.

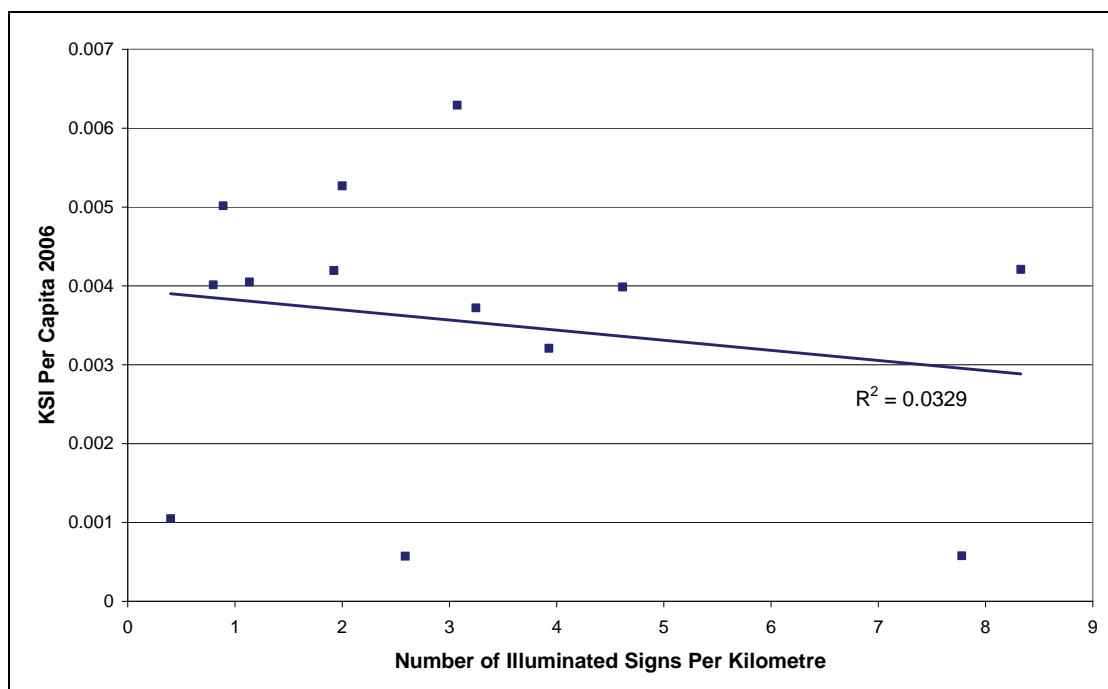

Figure 30 - A graph to show the lack of relationship between illuminated sign density and KSI per capita

It is clear from this figure that at this level of aggregation it is not possible to show any linkage between the number of illuminated signs per km and the KSI per capita (the R^2 value of 0.03 is very low). This does not by any means rule out such a relationship, it merely means that if such a

relationship does exist then it is not visible at this level of data due to interference from other factors involved.

8.3.1.7 Availability

In order to generate the metric for availability it was necessary to capture the quantitative magnitude of all the different factors that can cause the sign or bollard to be unavailable. The downtime while the units are being installed has already been discussed (Section 8.3.1.3) and values of one and five days per year (based on a ten year unit life expectancy) have been selected. The downtime for maintenance has been generated using data from Howard 2007 and is shown in Figure 31.

Activity	Unlit Sign	Lit Sign	LED or Electroluminescent Sign	Unlit Bollard	Lit Bollard	LED Bollard
Bulk Clean and Change Sign Annually (1 Day)		1			1	
Internal Wiring Test (1 Day)		1/6	1/6		1/6	1/6
Fault Repair (2 Days)	1/10	1/3	1/10		1/3	1/3
Category 3 Repairs (1 Day)		1/3.3		1/3.3	1/3.3	1/3.3
Clean of Sign Plate (0.5 Days)	1		1			
Clean only illuminated bollard (0.5 Days)				1/2	1	1/2
Replacement of damaged bollard (2 Days)				1/3.3	1/3.3	1/3.3
Bulb Replacement (0.5 Days)	0	1	1/10	0	1	1/10
Total Maintenance Downtime (Days Per Year)	0.7	2.64	0.97	1.16	3.64	2.09
Availability Metric (Scheme Delay of 1 Day)	1.43	0.27	0.51	0.86	0.22	0.32
Availability Metric (Scheme Delay of 5 Days)	1.43	0.13	0.17	0.86	0.12	0.14

Figure 31 - Data for and Calculation of Availability Metric

In this figure the numbers in the white boxes all represent the frequency with which each type of maintenance event occurs annually. For example, an internal wiring test occurs once every six years, so for 1/6th of a day each year. For each type of maintenance event a total downtime in days has been estimated based on judgement. These figures combined create a total annual downtime in days for each type of system from which it is immediately clear that some options are more vulnerable to downtime than others. The two dark grey columns at the bottom of Figure 31 show the calculated availability metric devised by taking the inverse of the sum of the total maintenance downtime plus the scheme delay of either one or five days.

In order to graph the cost benefit relationship this metric data needs to be accompanied by the Whole Life Cost data, which is shown in Figure 32.

	<i>Maintenance (per year)</i>	<i>Energy (per year)</i>	<i>Procurement – Cost Estimation</i>	<i>WLC (10 year life expectancy)</i>
Unlit Sign	£17.50	£0.00	£200.00	£375.00
Lit Sign	£137.09	£9.45	£900.00	£2,365.40
LED or Electroluminescent Sign	£28.42	£6.54	£245.00	£594.56
Unlit Bollard	£243.59	£0.00	£240.00	£2,675.90
Lit Bollard	£362.59	£28.40	£750.00	£4,659.90
LED Bollard	£245.42	£15.31	£320.00	£2,927.30

Figure 32 - The whole life cost data and calculation

The first two columns in this table are sourced directly from Howard 2007 while the third column contains the figures generated from histogram plots in Section 8.3. These three columns are then combined to produce a Whole Life Cost for the different options that reflects the procurement cost across a range of Local Authorities with the ongoing electricity and maintenance costs calculated for TfL. The Cost Benefit figure, Figure 33, was generated using these cost values and the availability values from Figure 31.

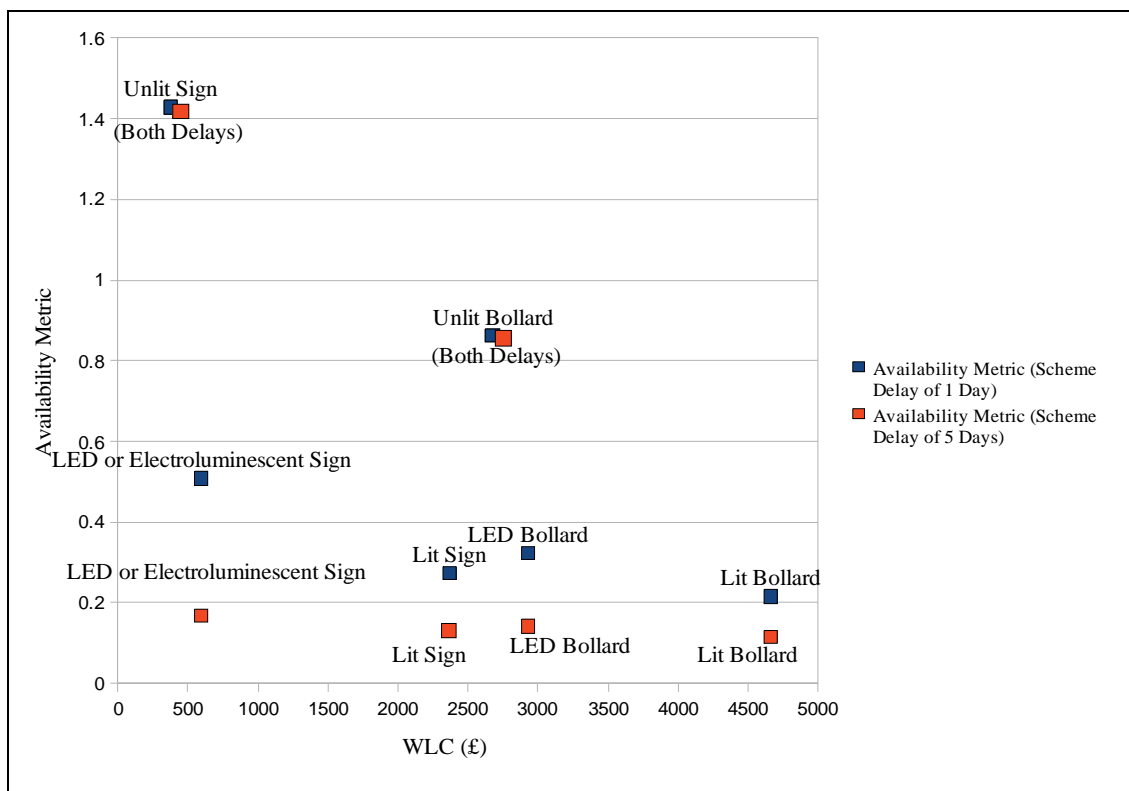

Figure 33 - Cost Benefit Graph for Availability Metric

This figure clearly shows that for a scheme delay of either 1 or 5 days, the use of unlit signs and bollards is much more cost effective than using units lit through traditional means as it is cheaper and incurs less downtime. LED or electroluminescent units are also less cost effective than unlit signs, though by a narrower margin as they have a lower maintenance profile.

Also demonstrated is the sensitivity of the calculation to the value used for total scheme delay for sign lighting. The survey returns indicated that whole schemes can be delayed by a long period, a value that is highly dependant on the specifics of the scheme. It is clear that in situations where there is already a suitable power infrastructure in place then the magnitude of this difference will be much lower, and conversely where there is no suitable infrastructure whatever the difference will be most marked.

By cross comparing the WLC and Availability metric values it is possible to determine the factor by which the unlit options score more highly than the traditionally lit, LED or electroluminescent options. The results are shown in Figure 34.

	Comparison	Factor of Increase in Availability	Factor of Reduction in Whole Life Cost
Signs	Unlit Over Lit (1 Day Scheme Delay)	5	6
	Unlit Over LED or Electroluminescent Sign(1 Day Scheme Delay)	3	1.5
	Unlit Over Lit (5 Day Scheme Delay)	11	6
	Unlit Over LED or Electroluminescent Sign(5 Day Scheme Delay)	8.5	1.5
Bollards	Unlit Over Lit (1 Day Scheme Delay)	4	1.5
	Unlit Over LED (1 Day Scheme Delay)	3	1
	Unlit Over Lit (5 Day Scheme Delay)	7.5	1.5
	Unlit Over LED (5 Day Scheme Delay)	6	1

Figure 34 - Factors of difference in availability and cost for unlit signs and bollards

8.4 Summary and conclusions

The cost benefit analysis confirms the intuitive answer; unlit traffic signs and bollards are not only cheaper to buy and install, but are also generally more reliable, as there is less hardware to install and fewer components that could fail. The results of the availability analysis, where availability is defined

as the inverse of number of days per year for which the unit cannot perform its full function, can be summed up as:

- **Unlit traffic signs experience 5 times greater availability and are 6 times cheaper than traditionally lit signs, and have 3 times greater availability and are 1.5 times cheaper than modern technology alternatives.**
- **Unlit traffic bollards experience 4 times greater availability and are 1.5 times cheaper than traditionally lit bollards, and have 3 times greater availability (though of similar whole life cost) than modern technology alternatives.**

It is also important to note that, in terms of availability, the delay associated with installing the lighting infrastructure plays a major role. It is recommended that if this analysis warrants further attention then it would be necessary to undertake a much larger sample for scheme delay and look at a wide range of different schemes within each local authority.

All else being equal, it is more cost effective to have unlit signs, as they are cheaper and incur less downtime throughout the course of their life. However this recommendation is countered by the observation that local authorities with a higher budget (per km of road) show a greater tendency to install more illuminated signs per km, indicating a predisposition to the technology by the practitioners.

8.5 Further work that could be undertaken

Within this project it has only been possible to undertake a limited cost benefit analysis, but there is certainly scope for further work to be done in this area. Further work to be considered may include some or all of the following topics:

- *Selective lighting of signs based on level of risk* – Currently many signs in areas of street lighting have to be lit. This applies equally to signs located on primary routes and those in residential streets. Work may be undertaken to consider the relative change in accident risk and likely severity of accidents on different types of road caused by removing of sign lighting. Factors may include:
 - Traffic flows – roads with higher flows are likely to have a higher accident risk
 - Typical vehicle speeds
 - Likely presence of pedestrians
- *Transferring of risk from drivers to highways authorities* – This is best illustrated with an example. If a sign warning of a side road junction ahead (sign 506.1) is placed in a built-up area with street lighting then it requires direct lighting. If an accident occurs at the entrance to one of these side roads and the sign lighting is not working, then the Local Highways Authority may be held liable. However, in a built up area with street lights it is reasonable to expect drivers to be aware of the potential for junctions, particularly where there are street lights, and so such a sign should hardly be necessary at all.



Figure 35 – Sign 506.1

Furthermore, if drivers become accustomed to being informed of every junction, they may learn to expect such a sign and their perception of the need to use due care and attention to assess the presence of junctions when driving may be affected. For any junctions that aren't signposted, the risk of accidents occurring may be increased.

- *Alternative uses of the money spent to save lives* – Consideration may be given to other uses for the money, currently spent to power and maintain traffic sign and bollard lighting, in order to save lives. For example, it is possible that if the money was spent on road education in schools, this may cause a large reduction in the number of road accidents involving children, which may more than compensate for a small increase in the number of accidents caused by traffic signs not being read due to the decrease in their conspicuity. Table 17 below shows the average value of accident prevention per casualty in 2006 – this may be considered to represent the 'benefit' of reducing accidents.

Accident/casualty type	Cost per casualty
Fatal	£1,489,450
Serious	£167,360
Slight	£12,900
Average	£48,170

Table 17 –Average value of prevention per casualty in 2006 (TSO, 2007b)

From the results of the questionnaire sent to local highways authority lighting engineers, it is estimated that around £1.29 billion is spent on annual maintenance of signs and bollards. If the provision of sign lighting accounts for, say, half of this figure then around £650 million is spent on providing sign and bollard lighting per year. Taking the fatal figures alone, this becomes cost effective if over 436 fatalities are avoided by lighting signs and bollards. Using the average figure, if 13,494 or more accidents are avoided by the use of such lighting then it can be considered cost effective. A study may be undertaken to suggest how spending this money in various ways is likely to affect accident rates.

- *Creation of new hazards* – This applies particularly to traffic islands and use of traffic bollards and signs to create road features such as pinch points, often used for speed reduction. These are extra hazards and provide the potential for vehicles to strike them; such accidents couldn't have occurred without their creation. It may be worth undertaking a study to consider whether overall more or less accidents occur because of the presence of these.

9 Recommendations

This short study into the possible relaxation of the requirements to light traffic signs and bollards has considered the views of key stakeholders and manufacturers, investigated current practice in other countries and carried out a cost/benefit analysis of different sign lighting options.

As a result of this investigation, the following recommendations are made:

1. Further work should be undertaken to investigate what methods can be used to improve the conspicuity of unlit traffic signs in areas with street lighting, for example the effective use of yellow reflectorised traffic sign backing boards, or providing standard regulatory or warning signs of a larger size.
2. Measurements of the conspicuity and legibility of various lit and unlit signs should also be undertaken in order to gather evidence as to whether and when sign lighting is required. This would involve both scientific measurements of luminance and subjective judgments of the visual performance of the signs. Off-road trials could be carried out using TRL's test track facility, and it is likely that the simulator at TRL could be used to carry out an initial study.
3. In order to reduce energy consumption and maintenance costs, local highways authorities should conduct an audit of their lit traffic signs and remove unnecessary sign lighting, for example, primary route and non-primary route directional signs, which do not need to be lit in areas with street lighting.
4. To reduce energy consumption and general traffic sign clutter, local highways authorities should consider the removal of unnecessary traffic signs. DfT state it is essential that all unnecessary warning signs are removed. Overuse of warning signs leads to a dilution of their influence on driver behaviour.
5. To reduce energy consumption and costs, local highways authorities should consider the use of LED or other energy efficient lighting for both externally and internally illuminated signs. The use of solar powered sign lighting and electroluminescent signs should also be considered.
6. To reduce installation time and costs, and to increase safety for workers and for the general public, local authorities should consider the use of low voltage lighting systems for their externally and internally illuminated signs. This would enable slitting rather than the normal excavation methods to be used.
7. In situations where safety is not likely to be compromised and where DfT is likely to give approval for the use of retroreflective self righting traffic bollards, applications from local highways authorities should be encouraged, but it is strongly recommended for safety reasons, these types of non-illuminated traffic bollards are maintained regularly, i.e. the retroreflective faces are cleaned or are replaced immediately if they are damaged.
8. Solar powered traffic bollards should also be considered for use instead of traditionally lit bollards, but as these bollards are single sided this should only be done after careful consideration of suitable situations where safety will not be compromised.
9. In order to reduce energy consumption and costs, all bollards or signs should be 'switched' so that they are only illuminated during hours of darkness.
10. Consideration should be made to whether the use of bollards for traffic calming applications, such as pinch points and traffic islands, is always appropriate. If some could be removed this would not only offer a significant cost saving, but also reduce the dangers faced by maintenance operatives who often have to work in the proximity of live traffic. If such work is undertaken care must be taken to ensure that all bollards necessary for aiding pedestrian crossing and highlighting hazards are retained.

A workable guidance document (Cooper and Mitchell, 2008) has been produced in order to inform Local Highways Authority engineers on when it is advisable and safe to seek relaxation of the regulations for lighting traffic signs and traffic bollards.

A technical paper (in PowerPoint format) will be produced to include the findings, conclusions and recommendations from this research. This paper will be presented to Local Highways Authorities at a relevant national lighting seminar.

Acknowledgements

The work described in this report was carried out in the Network Performance Group of TRL. The authors would like to thank the following for their assistance:

- Liz Newell-Hart (3M UK)
- Trevor Wren (Rennicks UK)
- Scott Horne (Avery Dennison GRPD Europe)
- Paul Grice and Eric Woodhouse (Simmons signs Ltd)
- Gaetan Dalle (Solagen Ltd)
- Peter Morris (TMP Traffic Management Products Ltd)
- Mark Walter (One2See Signs Ltd)
- Muriel Killin (Head of Traffic Signs Technical Branch, Department for Transport)

The authors are also grateful to Ewan Hardman who carried out the quality review and auditing of this report.

References

BSI (1980). BS 873 1980. Road traffic signs and internally illuminated bollards. Part 3: Specification for internally illuminated bollards.

BSI (2005). BS 8408:2005. Road traffic signs – Testing and performance of microprismatic retroreflective sheeting materials – Specification.

BSI (2006). BS 8442. Miscellaneous road traffic signs and devices. Requirements and test methods.

BSI (2007). BS EN 12899-1:2007. Fixed, vertical road traffic signs – Part 1: Fixed signs.

BSI (2007). BS EN 12899-2:2007. Fixed, vertical road traffic signs – Part 2: Transilluminated traffic bollards.

Cooper J and Mitchell J (2008). Review of the lighting requirement for traffic signs and bollards: Guidance document. PPR383, TRL, Crowthorne.

Department for Transport (2007a). Draft version of Traffic Signs Manual Chapter 3 – Regulatory Signs (due for publication – September 2008).
<http://www.dft.gov.uk/consultations/closed/trafficsigns2/trafficsignschapter3.pdf>

Department for Transport (2007b). Transport Statistics Great Britain.
<http://www.dft.gov.uk/pgr/statistics/datatablespublications/roadtraffic/roadlengths/>

European Road Safety Observatory (2007)

http://www.erso.eu/data/content/main_figures.htm#_Main_figures

Horberry T and Mitchell J (2006). IMPROVER Interim report Subproject 4 – Harmonisation of road signs and road marking on the TERN network from a safety point of view. Task 4.3 Internal Deliverable Report TRL Crowthorne.

Howard A (2007). Illumination of traffic signs, Whole life cost analysis of lighting options. Unpublished report, Mouchelparkman / Atkins Odlin ^{mp}

Mitchell J and Cooper J (2008). Review of the lighting requirement for traffic signs and bollards. Inception report UPR/T/005/08 (Unpublished), TRL, Crowthorne.

Thompson S, Mitchell J and Flint A (2006a). A trial to measure the effects of dew on vertical traffic signs. Report PPR 116 (Published), TRL, Crowthorne.

Thompson S, Mitchell J, Chequer A and Flint A (2006b). Protective overlay films on traffic signs: further research work - Revision A (Final). Report PPR 118 (Published), TRL, Crowthorne.

TSO (2002). The Traffic Signs Regulations and General Directions (TSRGD) 2002.

TSO (2004). Traffic Signs Manual Chapter 4 – Warning Signs.

TSO (2007a). The Construction (Design and Management) Regulations 2007.

TSO (2007b). Road Casualties Great Britain 2006.

Appendix A. Obtaining authorisation for unlit bollards

Section 64 (2) of the Road Traffic Regulation Act 1984 enables authorisation of signs of a character not stipulated within TSRGD 2002. The Applications must include a detailed drawing of the sign / bollard and a plan or description of the region in which it is to be used.

Appendix A.1 details the authorisation process for England and Wales, while Appendix A.2 details the procedure for Scotland. Separate procedures apply in Northern Ireland where neither the Road Traffic Act 1984 nor TSRGD 2002 applies.

A.1 Instructions to obtain authorisation for unlit bollards in England and Wales

In England this authorisation is obtained via:-

Department for Transport,
Traffic Management Division, TM4,
76 Marsham Street,
London SW1P 4DR

In Wales authorisation is obtained via:-

Road Network Management Division
Transport Wales
Welsh Assembly Government
Cathays Park
Cardiff CF10 3NQ

Overleaf is shown instructions from the TMP website for how this is done in practice.



In order to obtain authorisation for the use of the TMP Flecta® and Heritage bollards from the DfT, please follow the steps below:

- 1 Reproduce the attached Word document on your letterhead, filling in your Council details where indicated.
- 2 Print 4 copies of each of the following drawings:
 - TMP 4200/040 Left
 - TMP 4200/115
 - TMP 4200/077 Heritage D610 Left
 - TMP 4200/092 Heritage D611
- 3 Send the letter and drawings to the DfT at the following address:

Kate Soley-Barton
Traffic Management Division
TM4
Department for Transport
3/21
Great Minster House
76 Marsham Street
London
SW1P 4DR

Traffic Management Division
TM4
Department for Transport
3/21
Great Minster House
76 Marsham Street
London
SW1P 4DR

Dear xxxx

TMP Non-Illuminated Bollard

I am writing to seek authorisation to use the TMP Non Illuminated Bollard in the borough of (Please enter your council details).

Please therefore find attached four copies of the appropriate D610 and D611 drawings I understand you require to enable you to process this request.

I look forward to receiving your written confirmation that authorisation can be given by DfT subject to compliance with your conditions.

Yours sincerely,

A.2 Instructions to obtain authorisation for unlit bollards in Scotland

In Scotland authorisation is obtained via

The Scottish Government Transport Directorate,
 Bus, Road Safety and Local Roads Policy,
 Area 2F(North) Victoria Quay,
 Edinburgh, EH6 6QQ

and the application forms for this are below.

Your ref:

Our ref:

APPLICATION FOR AUTHORISATION OF NON-PRESCRIBED TRAFFIC SIGNS AND SPECIAL DIRECTIONS (LOCAL ROADS)
--

TO:- The Scottish Government, Transport Directorate, Bus, Road Safety and Local Roads Policy, Area 2F(North) Victoria Quay, Edinburgh, EH6 6QQ

Please consider issuing an authorisation or special direction for the following:

TITLE/DESCRIPTION OF SIGN/SCHEME

NAME OF TRAFFIC AUTHORITY

ENCLOSURES	TICK to confirm inclusion
5 copies of each site plan, showing the locations proposed for each sign to be authorised. <i>(N.B. The Scottish Government can be asked to advise in particular cases whether a brief written description of the site or sites would be acceptable instead)</i>	<input type="checkbox"/>
5 copies of each sign drawing, clearly marked with colours and sizes.	<input type="checkbox"/>
For regulatory signs:- A statement of the restriction(s), requirement(s) or prohibition(s) to be indicated by each sign design (or a draft or made TRO).	<input type="checkbox"/>
For other signs:- A statement of the purpose of/reasons for erecting a nonprescribed sign	<input type="checkbox"/>

**THE SIGNING SCHEME DESIGNER SHOULD COMPLETE
 THE CHECKLIST OVERLEAF AND SIGN THE APPLICATION
 FORM BEFORE FORWARDING IT.**

CHECKLIST <i>to be completed by the signing scheme designer</i>	Mark YES or NOT APPLICABLE as appropriate
I CONFIRM THAT:-	
1. There is no suitable sign prescribed in TSRGD 2002 for this purpose;	
2. The signs are appropriate for their proposed site and purpose;	
3. The signs follow the normal design rules and correspond as closely as possible to the nearest available prescribed sign or DfT working drawing (drawing ref no.....) <i>(N.B. The Scottish Government can advise in particular cases on availability of working drawings from The Stationery Office or DfT HQ)</i>	
4. The sign drawings are marked with dimensions in millimetres, and show all the colours to be used;	
5. The sizes of the signs and lettering are appropriate to the speed of traffic on the road (Ref: DOT Local Transport Note 1/94)	
6. The intended illumination / reflectorisation is stated;	
7. The site plans are legible, with the positions of the non-prescribed signs and any relevant prescribed ones clearly marked;	
8. In the case of regulatory signs including those for restricted zones, the signs correctly indicate the restriction(s)/ requirement(s)/ prohibitions which will apply at the sites where they are to be erected, and have the agreement of the police;	
9. In the case of variable message signs or light signals the appropriate equipment approval has been or will be issued by the Highways Agency;	
ANY OTHER RELEVANT INFORMATION: 	

SIGNED:.....

NAME (block caps)

Address:.....

Phone no:

Fax no:.....

Date:.....2008

Appendix B. Sample of questionnaire sent to local authorities



A partnership led by the County Surveyors Society, has commissioned TRL to conduct a study to challenge the requirement to illuminate many traffic signs and bollards in lit areas. We need your assistance to establish the costs and identify problems associated with illuminating traffic signs and bollards. We would appreciate it if you would complete this survey to help us in this.

What is the length of maintained highway in your area?

km

Please provide your estimate of the total cost of installing a typical illuminated traffic sign including all materials, electrical supply, excavation and temporary traffic management?

£

What is the equivalent figure for a similar non-illuminated sign?

£

And for an illuminated bollard?

£

And a non-illuminated bollard?

£

How much longer does it take to implement a highway safety scheme due to the current requirement to provide electrical supply to illuminate traffic signs and bollards?

What is the total budget for illuminated traffic signs and bollards in your area? i.e. energy costs, routine inspection, cleaning and temporary traffic management etc.

£

Does this figure include?

- Night scouting
- Lamp changing
- Cleaning
- Temporary traffic management costs
- Responsive maintenance
- Other

Approximately how many illuminated traffic signs do you have in your area?

Approximately how many illuminated traffic bollards do you have in your area?

Name
Email
Highway Authority

<input type="text"/>
<input type="text"/>
<input type="text"/>

Appendix C. Questionnaire on practice in other countries



In the UK there is a legal requirement for permanent signs that regulatory and many warning signs, if sited within 50m of a lamp which forms part of a system of street-lighting, must be illuminated at night by means of internal or external lighting. At TRL we are reviewing the need for this requirement. As part of this review we are studying how the law in relation to the lighting of signs differs around the world. We would appreciate it if you could fill out this questionnaire about the requirements in your country/state.

Do you have a similar requirement for the lighting of traffic signs/bollards?

- Yes
- No

If yes, what type of signs must be lit?

- Regulatory signs
- Warning signs
- Directional signs
- Bollards
- Other.....

If no, are there any special circumstances in which you do light signs/bollards?

- High accident risk areas
- Signs on the offside of a road
- Signs mounted above a certain height. What height?.....
- Other.....

Do you make traffic signs/bollards more conspicuous in towns/cities where there are high levels of background illumination?

- Yes
- No

If so how?.....

Do you use any types of low powered signs/bollards, e.g. solar powered?

- Yes
- No

If so, what type?.....

Please return you completed questionnaires to:

Kathryn Stafford
TRL
Crowthorne House
Wokingham
Berkshire
RG40 3GA
UK

kstafford@trl.co.uk

Appendix D. Installation instructions for various types of sign

D.1 Installation guidance for Solagen Solar Powered sign lighting system:

SOLARSIGN TYPE F™ INSTALLATION MANUAL

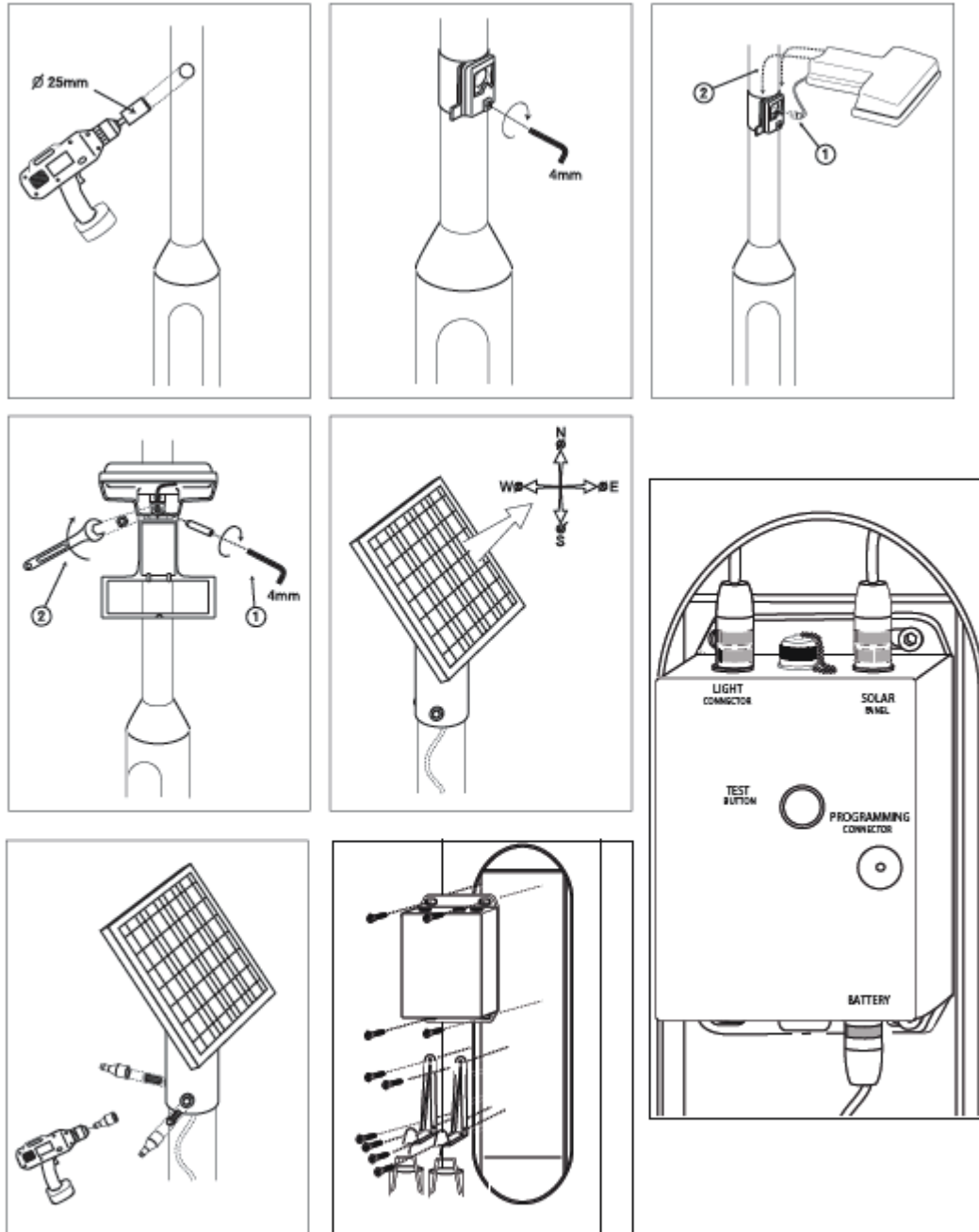

SOLAGEN LTD
Unit 8 Easter Court, Woodward Avenue, Westerleigh Business Park, Yate, BS37 5YS
T +44 (0) 1454 318260 F +44 (0) 1454 324960 enquiry@solagen.net



D.2 Installation instructions for One2See's electroluminescent sign

Electroluminescent Road Traffic Sign Installation and Operating Instructions

Introduction.

The One2seedp electroluminescent road traffic sign is a revolutionary product that requires no external conventional lighting source. The road sign is illuminated by an electroluminescent sheet built into the sign face construction. The electroluminescent sheet is powered and controlled by a dedicated electronic Driver housed in an aluminium enclosure designed to fit into the top of the sign post. The driver enclosure includes a post top cap housing a photocell to automatically turn the sign illumination on between the hours of dusk and dawn.

Installation.

Care must be taken when installing this product to prevent injury to persons or damage to equipment. Before commencing installation IT IS ESSENTIAL that the mains electrical supply is disconnected and made safe. Installation and wiring must be carried out in accordance with BS7671 (IEE wiring regulations), or national equivalent standards by suitably qualified personnel.

Road Traffic signs must be installed in accordance with BSEN12899 & TSRGD 2002, or national equivalents.

1. Ensure mains supply has been disconnected and made safe.
2. Disconnect and remove existing road sign and all associated luminaires, controls and wiring (if applicable). Remove post cap.
3. Drill 20mm Dia. hole in post on centre-line of sign face and fit cable grommet supplied. For correct positioning allow for top of sign to be level with top of post.
4. Insert pre-wired cable from back of sign, through grommet and into post. Allow plug to drop to base of post. Install sign onto post using proprietary U bolts fitted to the channels on the back of the sign. Ensure all cable is pushed into post and that grommet on back of sign makes a weathertight seal onto the post.
5. Insert pre-wired cables from base of driver into post top and allow cables to drop to base of post.
6. Carefully insert driver into top of post, making sure that flat side of driver (with rating label fitted) faces the back of the sign, to allow driver to pass in front of cable from sign. Ensure cables are not trapped as driver is lowered into post top.
7. When driver is fully inside post top, secure cap to post with 3 security Allen screws supplied.
8. Carefully cut to length and strip back the outer coverings of the 4 core cables from the sign and the Driver. Do not strip the insulation on the individual cores as the connectors supplied automatically do this. Connect the individual cores together in the base of the post, colour to colour, (Red to Red, Orange to Orange, Black to Black and Brown to Brown) using the four separate connectors supplied (see typical wiring/connection diagram below). If necessary secure the connectors within post base to prevent them lying in water/debris.
Please refer to manufacturer's Data Sheet supplied with the connectors for connector installation instructions, specifications, etc.
9. Connect mains 3 core cable to incoming electricity termination device (Isolator, RCD, terminal block, etc) in base of post in accordance with the following colour codes:
Brown: Live
Blue: Neutral
Green/Yellow: Earth.
The driver MUST be connected to earth.
Metal sign posts must also be connected to earth.
The sign face is of double insulated construction – no earth connection is required.
10. Ensure all wiring is safe and secure, and reconnect mains supply.

Operation.

1. The sign is designed to only illuminate at night. The nature of the light source is such that illumination may not be readily visible in sunlight or strong daylight, and it may therefore be necessary to cover the sign face to observe illumination during testing.
2. Temporarily cover the photocell on the top of the driver/post to simulate darkness.
3. Wait up to 5 minutes and check that sign has illuminated.
4. Uncover photocell and check that sign illumination turns off.
5. Re-cover photocell and re-check that sign again illuminates (This checks that both circuits of the electroluminescent material are operating correctly).
6. Remove covers from photocell and sign. Ensure all wiring and fixings are secure. Refit post base cover, and wipe over sign face with a damp cloth.

Maintenance.

The illuminated sign and driver require no maintenance during their lifetime.

To maintain legibility, the sign face should be cleaned periodically in accordance with the recommendations of BSEN12899.

The sign face and driver contain sensitive electronic materials and should NOT be subjected to Insulation resistance (Meggar) testing.

Typical Installation Diagram

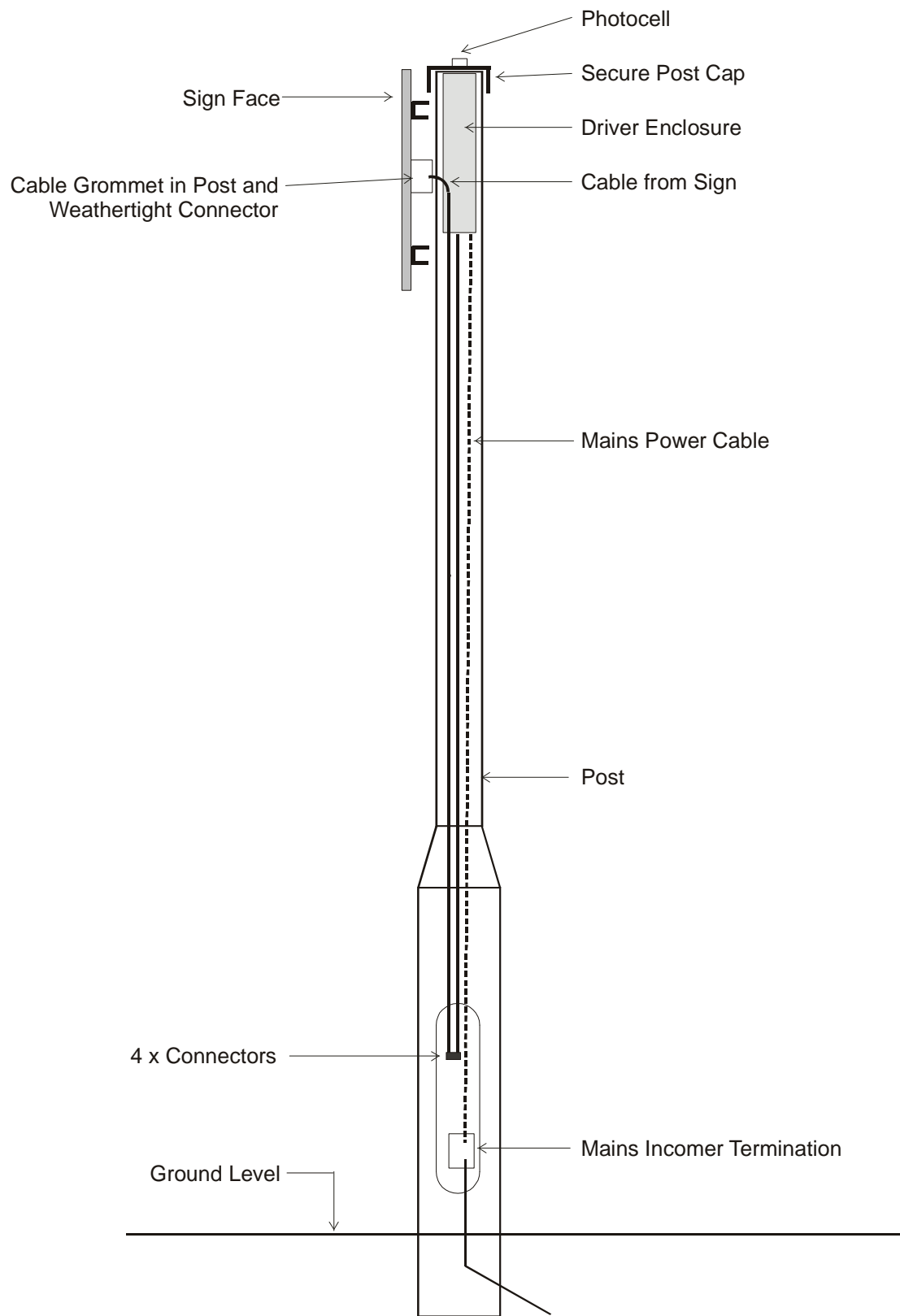

Typical Wiring/Connection Diagram

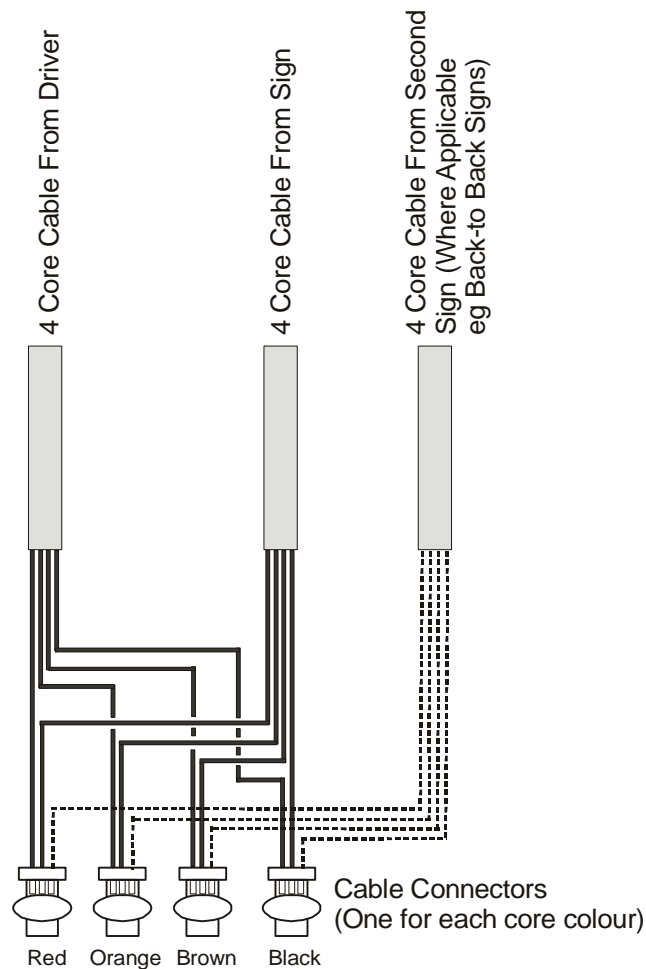

Sign Wiring Connector Arrangement

Specifications.

Driver :

Input : 220-240V ac 50Hz

Output (Max): 150V rms 200-600Hz

Ambient temperature : -10.....+25C

Conforms to BSEN61347-11: 2002 / BSEN61347-1: 2000

IP44 (Post cap)

Sign :

Operating voltage 150V rms 200-600Hz

Double-insulated construction - no earth connection required

IP66

Designed to conform to BSEN12899-1: 2001 where applicable

© One2seedp. World Patents Pending.

D.3 Installation instructions for TMP bollards



FOUNDATION DETAILS FOR THE TMP CAST-IN CAGE
FOR USE WITH ALL TMP PASSIVE SAFE TRAFFIC SIGNS

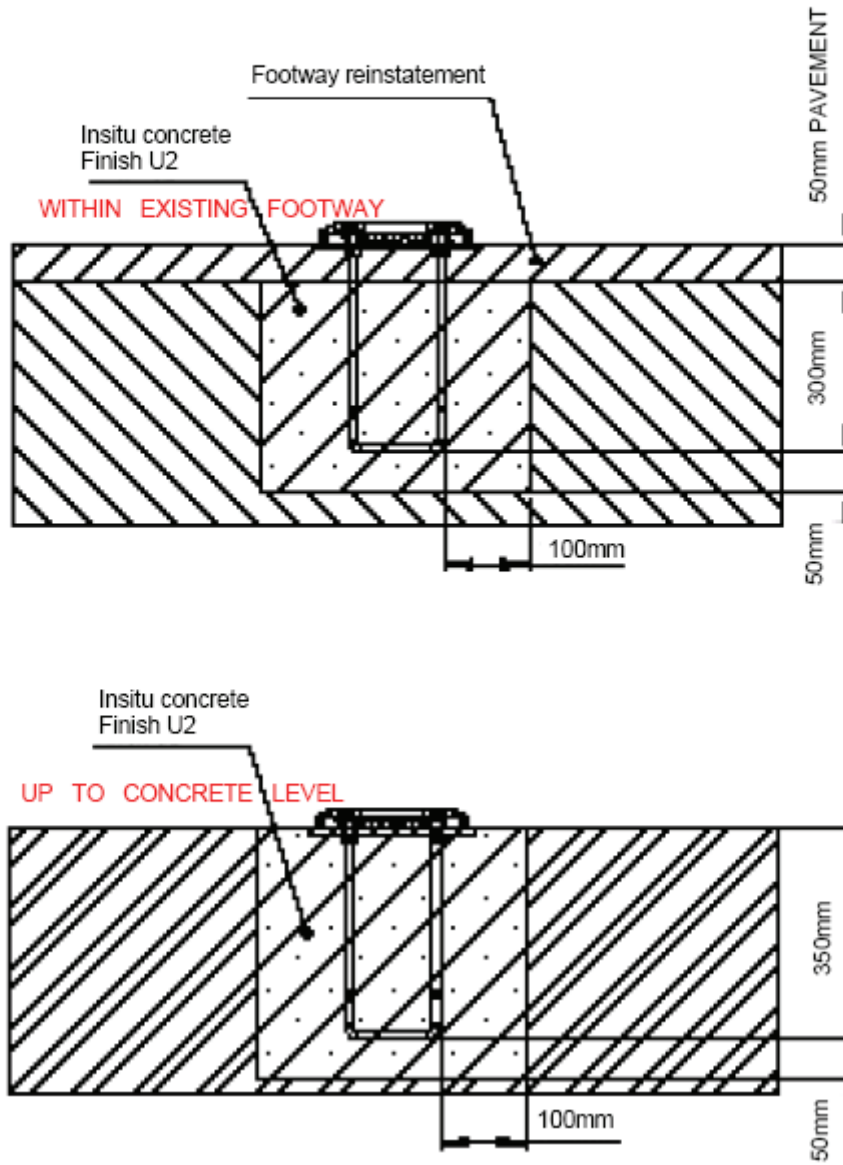



TMP FIXED BASE

INSTALLATION INSTRUCTIONS

Components

- 4 x M12 Plastic Anchors
- 4 x M12 Bolts
- 4 x Metal Washers

Materials Needed for Installation

- Drill with ½" Bit
- Small Hammer
- 5/16" Allen Key
- Suitable sized Socket

Installation Instructions

- 1 Place Fixed Base on surface, align to desired position (direction arrow on baseplate). Using the base as a template, mark the (4) holes to establish pattern for drill.
- 2 Drill four (4) holes 80mm deep using a ½" Bit. Clean debris from holes.
- 3 Using a hammer gently tap the anchors into the holes.
- 4 Place the base over the anchors. Put washer onto bolts. Start bolt through base hole into plastic anchor. Use socket to tighten bolts onto base.
- 5 Place the sign or post onto base, check for proper alignment, hand tighten all four socket cap bolts. Use 5/16" Allen Key to tighten bolts.

Review of the lighting requirement for traffic signs and bollards



Improvements in the quality of street lighting and the development of high performance retro-reflective signing materials potentially make unlit traffic signs more visible. TRL conducted a technical review, commissioned by Transport for London, into the requirement for local highway authorities to comply with the current statutory requirements for lighting traffic signs and bollards in areas with street lighting. As well as reviewing the regulations and the appropriate British Standards, a whole life cost benefit exercise was conducted. This covered the costs of different types of traffic signing material, their luminaires, life expectancy and maintenance. In addition, the costs, life expectancy and maintenance of alternative types of illuminated traffic sign were established. A workable guidance document was produced to inform local highway authority engineers when it is advisable and safe to relax the statutory requirements for lighting traffic signs and traffic bollards as part of a traffic management scheme in areas with street lighting. Practical guidance was also supplied covering the use of all types of lit and unlit traffic signs. Documentation was produced describing the process of obtaining official authorisation from the appropriate government department in order to relax the use of traffic signing without external illumination in areas with street lighting.

Other titles in this series

- SL1** Review of the class and quality of street lighting. G I Crabb, R Beaumont and D Webster. TRL Published Project Report PPR380. 2009
- SL2** Invest to save – sustainable street lighting. P Fox. Mouchel. 2009
- SL3** Review of luminaire maintenance factors. A Sanders and A Scott. Mott MacDonald. 2009
- SL4** The use of passively safe signposts and lighting columns. G L Williams, J V Kennedy, J A Carroll and R Beesley. TRL Published Project Report PPR342. 2009
- SL5b** Guidance on the lighting requirement for traffic signs and bollards. J Cooper and J Mitchell. TRL Published Project Report PPR383. 2009

TRL
Crowthorne House, Nine Mile Ride
Wokingham, Berkshire RG40 3GA
United Kingdom
T: +44 (0) 1344 773131
F: +44 (0) 1344 770356
E: enquiries@trl.co.uk
W: www.trl.co.uk

Published by



IHS
Willoughby Road, Bracknell
Berkshire RG12 8FB
United Kingdom
T: +44 (0) 1344 328038
F: +44 (0) 1344 328005
E: trl@ihs.com
W: <http://emeastore.ihs.com>

Price code: 3X

ISSN 0968-4093

ISBN 978-1-84608-773-8



9 781846 087738

SL5a/PPR382